

This report contains the collective views of an international group of experts and does not necessarily represent the decisions or the stated policy of the World Health Organization.

WORLD HEALTH ORGANIZATION

TECHNICAL REPORT SERIES

No. 46

**EXPERT COMMITTEE ON
INSECTICIDES**

Third Report

	Page
1. Nomenclature and definitions of spraying and dusting apparatus	3
2. Specifications for stirrup-pump-type sprayers	10
3. Specifications for hand dusting apparatus	14
4. Specifications for chemical-resistant materials	19
5. Specifications for cut-off valves	20
6. Specifications for clamp-type hose-connexions	22
7. Specification chart for spraying apparatus	23
8. Mechanically operated compressors for compression sprayers	24
9. Suggestions for future discussions	24
Annex 1. Test for strength of stirrup-pump-type sprayer plunger-shaft	26
Annex 2. Test of delivery	26
Annex 3. Performance test for agitator	26
Annex 4. Physical requirements for hose	27
Annex 5. Tests for hose	28
Annex 6. Durability tests for cut-off valves	30
Annex 7. Specification chart for compression-type sprayers	31
Annex 8. Comparative data on efficiency of compression sprayers utilizing manual and mechanical compression	35

WORLD HEALTH ORGANIZATION

PALAIS DES NATIONS

GENEVA

AUGUST 1952

EXPERT COMMITTEE ON INSECTICIDES

Third Session

Savannah, Ga., 30 July-4 August 1951

Members :

- Dr. A. L. Berti, Chief, Division of Malariology, Directorate of Public Health, Ministry of Health and Social Welfare, Maracay, Venezuela
- S. H. Fryer, Head, Engineering Section, Chemical Defence Experimental Establishment, Ministry of Supply, Porton, Wilts., United Kingdom
- F. W. Knipe, Rockefeller Foundation, New York City, N.Y., USA
- A. Lemierre, Ingénieur du Génie rural, Centre de Recherches et d'Expérimentation de Génie rural, Direction générale du Génie rural et de l'Hydraulique agricole, Ministère de l'Agriculture, Paris, France
- Dr. Rajindar Pal, Assistant Director, Malaria Institute of India, New Delhi, India (*Vice-Chairman*)
- Dr. S. W. Simmons, Scientist Director, Chief, Technical Development Services, Communicable Disease Center (US Public Health Service), Savannah, Ga., USA (*Chairman*)

Secretary :

J. W. Wright, Malaria Section, WHO

The report on the third session of this committee was originally issued in mimeographed form as document WHO/Insecticides/14, 27 August 1951.

NOTE

The mention of manufacturers' products does not imply that they are endorsed or recommended by the World Health Organization in preference to others of a similar nature which are not mentioned.

EXPERT COMMITTEE ON INSECTICIDES

Third Report¹

The third session of the Expert Committee on Insecticides was held at the laboratories of the Technical Development Services, Communicable Disease Center (US Public Health Service), Savannah, Ga., from 30 July to 4 August 1951.

Mr. J. W. Wright, Secretary of the committee, delivered an address at the opening meeting on behalf of the Director-General and explained the organization, functions, and policies of the World Health Organization as related to expert committees, particularly the Expert Committee on Insecticides.

Election of officers

Dr. S. W. Simmons was elected Chairman and Dr. Rajindar Pal, Vice-Chairman, of the committee.

Agenda

The provisional agenda was adopted without alteration. Since the agenda dealt exclusively with insecticide-dispersing equipment, the deliberations of the committee were greatly facilitated by the fact that the Technical Development Services were able to place their facilities at its disposal.

1. Nomenclature and Definitions of Spraying and Dusting Apparatus

The Expert Committee on Insecticides, at its third session, considered the establishment of standard nomenclature for types and parts of spraying

¹ The Executive Board, at its ninth session, adopted the following resolution :
The Executive Board

1. NOTES the report of the Expert Committee on Insecticides on its third session ;
2. THANKS the members of the committee for their work ;
3. AUTHORIZES publication of the report, and
4. NOTES that this report was prepared by a committee of experts convened by the World Health Organization at the request of several governments.

(Resolution EB9.R97, *Off. Rec. World Hlth Org.* 40, 34)

equipment. After discussion and careful consideration, the following list of names and definitions were adopted as "standard". The committee recommends that this nomenclature have worldwide distribution to government departments and all manufacturers of spraying equipment.

1.1 Sprayers

1. *Compression sprayer* (synonyms : pneumatic sprayer, shoulder-type sprayer, barrel sprayer). A pneumatic, pre-pressurized apparatus designed for the application of insecticides, herbicides, and fungicides in solution or suspension, based on the principle of positive pressure. The pressure is normally furnished by a hand-operated pump incorporated in the apparatus ; but it may, however, be supplied from an independent source. The tank is usually circular in shape, with a working capacity of approximately 7.6 to 15.1 litres (2 to 4 US gallons). The sprayer is fitted with one or two straps for convenience in carrying. (This was referred to as a "knapsack/compression sprayer" in the report on the committee's second session.²)

2. *Flame sprayer*. An apparatus designed to generate a flame of very high intensity (about 1,100°C, i.e., 2,000°F) for the destruction of weeds, grasses, garbage, and insect pests. It is similar to the normal compression sprayer, the nozzle and the cut-off valve being replaced by a burner and a needle valve, respectively.

3. *Hand sprayer*. A light, hand-activated, pneumatic sprayer, normally of not more than 950-ml (1-US-quart) capacity, used for the application of liquid insecticides.

4. *Knapsack sprayer*. An apparatus designed for the application of insecticides, herbicides, and fungicides in solution or suspension. It is always carried on the back by two straps passing over the shoulders of the operator. A continuous discharge is achieved by the constant operation of a pump incorporated within the tank. The tank may be shaped to the contour of a man's back or may be provided with a similarly shaped shield.

5. *Power sprayer*. A sprayer in which the liquid insecticide is forced through the nozzle under pressure generated by a motor-driven hydraulic or pneumatic pump. (This definition does not include misting or thermal aerosol machines. These could be dealt with at a future session.)

6. *Stirrup-pump sprayer* (synonym : bucket-pump sprayer). An apparatus designed for the application of insecticides, herbicides, and fungicides

² *World Hlth Org. techn. Rep. Ser.* 1951, **34**, 27 (section 5.1)

in solution or suspension. Single- and double-barrelled types are available, but in both the basic principle is the same. The single-barrel type consists of a barrel, a hollow plunger-shaft moving within the barrel (which acts as an air chamber), a plunger, and the necessary valve assembly. In the double-barrelled type the main barrel forms the air chamber with the pump and plunger in a second barrel alongside. The plunger in both cases is operated manually by an up-and-down movement within the barrel. The sprayer may be held within a bucket or similar container by an adjustable foot stirrup, or it may be fitted into a tank. (This was referred to as a "stirrup pump" in the report on the second session.³)

7. *Telescopic sprayer* (synonyms: trombone sprayer, spray wand). A hand sprayer composed of two cylinders working one within the other in a telescopic manner. This movement creates positive and negative hydraulic pressure for intake and discharge of the liquid.

8. *Wheelbarrow sprayer* (synonym: cart sprayer). A portable sprayer in which the pump and tank are transported by a wheelbarrow-type carrier.

1.2 Dusters

1. *Hand duster*. A small, light-weight duster operated by hand.

2. *Knapsack duster*. An apparatus for the application of insecticides in the form of dusts, designed to be worn on the back and operated by a hand lever which extends in front of the operator.

3. *Power duster*. An apparatus from which dust is expelled by a motor-generated air-stream.

4. *Rotary duster* (synonym: powder duster). An apparatus designed to be worn in front of the operator, suspended by straps from the shoulders at a convenient height for cranking. The dust is expelled from the tank by a hand-operated rotor.

5. *Traction duster*. An apparatus mounted on a wheeled-type carrier, from which dust is expelled by a mechanically operated rotor driven by the traction.

1.3 Sprayer parts

1. *Agitator*. A mechanism used for agitating materials in the tank.

2. *Air chamber* (synonym: pressure barrel). A chamber incorporated within the pump mechanism for the purpose of stabilizing pressure.

³ *World Hlth Org. techn. Rep. Ser.* 1951, 34, 35 (section 5.3)

3. *Automatic cut-off valve* (synonym : automatic shut-off valve). A device fitted to the discharge line which automatically cuts off the flow of insecticide at a pre-set pressure. (This was referred to as "automatic shut-off valve" in the report on the second session.⁴)

4. *Barrel*. A smooth-bore metallic cylinder. One barrel is fitted with the plunger shaft and a second barrel acts as an air chamber. (Applies to stirrup pumps.)

5. *Barrel clamp*. A metal clamp attached to the barrel to which is fitted the vertical bracket of the stirrup. (Applies to stirrup pumps.)

6. *Burner* (synonym : torch, gun). The part of the flame sprayer at the end of the flame lance into which is incorporated the generating pan, wick, burner nozzle, and burner shield. (Applies to flame sprayers.)

7. *Burner coil* (synonym : pre-heater coil). A coiled extension of the lance within the burner shield which acts as a preheating mechanism for vaporizing the liquid fuel. (Applies to flame sprayers.)

8. *Burner handle* (synonym : burner shaft). The handle by which the burner is carried and directed. (Applies to flame sprayers.)

9. *Burner nozzle*. The mechanism, situated at the discharge end of the flame lance, which controls the flow of vaporized fuel being forced through the liquid line under pressure. (Applies to flame sprayers.)

10. *Burner shield*. A cylindrical tube, open at both ends, which controls the flame so that it may be directed forward at the discretion of the operator. The shield also aids in preheating the liquid fuel. (Applies to flame sprayers.)

11. *Capillary siphon-tube*. A capillary tube extending from the nozzle approximately to the bottom of the tank. (Applies to liquid sprayers for hand use.)

12. *Check valve* (synonyms : poppet valve, air check). The non-return valve, fitted to the outer end of the pump, which allows the passage of air under pressure from the pump to the tank. (This was referred to as a "poppet valve" in the report on the second session.⁵)

13. *Combined strainer assembly and foot valve* (synonym : combined filter assembly and foot valve). A comprehensive term covering all the parts comprising the pump inlet, strainer, and non-return valve.

14. *Cone spray* (synonym : cone-shaped spray). A spray pattern taking the form of a cone, the apex of which is based on the nozzle aperture. (This was referred to as a "cone-shaped spray" in the report on the second session.⁶)

⁴ *World Hlth Org. techn. Rep. Ser.* 1951, 34, 30 (section 5.1.8, paragraph (3))

⁵ *World Hlth Org. techn. Rep. Ser.* 1951, 34, 29 (section 5.1.4, paragraph (4))

⁶ *World Hlth Org. techn. Rep. Ser.* 1951, 34, 30 (section 5.1.8, paragraph (4))

15. *Coupling fittings*. Male or female fittings connecting the hose to the cut-off valve, the cut-off valve to the lance, and one extension lance to another.

16. *Cup leather* (single) (synonyms : leather piston, cup washer, pump plunger leather, pump leather, plunger shaft, leather cup, leather bucket). The leather which forms a compression seal when fitted to the plunger shaft and inserted into the barrel.

Cup leather (double) (synonyms : double cup-leather assembly, double cup-washer assembly). Two cup leathers fitted back to back which form a compression seal when attached to the plunger shaft and inserted into the pump barrel.

17. *Cup-leather disc* (synonym : cup-washer disc). Circular metal disc fitted inside the cup leather.

18. *Cup-leather nut* (synonym : cup-washer nut). A hexagonal metal nut, screwed onto the end of the plunger shaft, and adjusted to lock the plunger assembly in place.

19. *Cut-off valve* (synonyms : control valve, spray-control valve, jet spray pistol, spray gun assembly, stop valve, spray-control lever, shut-off nozzle, pistol assembly). The hand-operated mechanism situated between the tank outlet and the nozzle which controls the flow of liquid from the sprayer. (This was referred to as a "spray-control valve" in the report on the second session.⁷)

20. *Delivery outlet*. An adapter on the sprayer to which the hose is attached.

21. *Diaphragm-type pump*. A pump in which pressure is exerted by a diaphragm, as opposed to that in which a plunger or piston is used. (Usually applies to knapsack sprayers.)

22. *Discharge line* (synonym : liquor line). The whole of the liquid-discharge line from the tank to the nozzle, including hose, cut-off valve, lance, and extension lance. (This was referred to as "liquor line" in the report on the second session.⁸)

23. *Drive*. That part of the mechanism which transmits the motive power to the pump—usually a shaft, belts and pulleys, or gears.

24. *Extension lance* (synonyms : extension tube, extension rod, extension pipe). A rigid, seamless tube of chemical-resistant material which extends the length of the lance. (This was referred to as an "extension rod (lance)" in the report on the second session.⁹)

⁷ *World Hlth Org. techn. Rep. Ser.* 1951, **34**, 30 (section 5.1.7, paragraph (3))

⁸ *World Hlth Org. techn. Rep. Ser.* 1951, **34**, 30 (section 5.1.8, paragraph (3))

⁹ *World Hlth Org. techn. Rep. Ser.* 1951, **34**, 29 (section 5.1.7, paragraph (2))

25. *Extension skirt* (synonym : tension skirt). The metal strip extending below the tank bottom which protects it from damage. (Applies to compression sprayers.)

26. *Filler cap*. The cover which closes the filler hole.

27. *Filler hole* (synonym : filling hole). The aperture through which the insecticide is introduced into the tank. (This was referred to as a "filling hole" in the report on the second session.¹⁰)

28. *Flat spray* (synonyms : flat-fan spray, fish-tail spray, flat-broom spray). A spray pattern taking the form of a flat fan, the apex of which is based on the nozzle aperture. (This was referred to as a "flat fan spray" in the report on the second session.¹¹)

29. *Foot rest* (synonym : foot stirrup). Foot rest attached to the bottom of the vertical bracket. (Applies to stirrup pumps.)

30. *Gasket*. Oil- and chemical-resistant packing used in making sprayer joints air- and liquid-tight.

31. *Generating pan*. The pan, located within the burner shield, directly under the burner nozzle which holds ignited liquid fuel while the burner nozzle is being preheated. (Applies to flame sprayers.)

32. *Gooseneck attachment*. An attachment about 20 cm (8 inches) long and curved to an angle of approximately 120°, placed at the extreme end of the lance just before the nozzle.

33. *Handles, "D"- or "T"-type*. The types of handles fitted to the external end of the plunger shaft on which the operator exerts pressure for the operation of the pump.

34. *Hose* (synonym : flexible tubing). The chemical- and oil-resistant, flexible tube connecting the outlet aperture of the sprayer to the cut-off valve. (This was referred to as "flexible tubing" in the report on the second session.¹²)

35. *Hose clamp*. A metal strip which, on having its ends brought together by a screw, binds the hose to the tank outlet, the cut-off valve, or other part of the spraying apparatus in an air- and liquid-tight connexion.

36. *Lance* (synonyms : spray lance, wand). The rigid, seamless tube of chemical-resistant material connecting the cut-off valve to the nozzle. (This was referred to as an "extension rod (lance)" in the report on the second session.¹³)

37. *Mounting* (synonyms : base, frame). A frame upon which the component parts of the unit are assembled. (Applies to power sprayers.)

¹⁰ *World Hlth Org. techn. Rep. Ser.* 1951, 34, 29 (section 5.1.5)

¹¹ *World Hlth Org. techn. Rep. Ser.* 1951, 34, 29 (section 5.1.7, paragraph (1))

¹² *World Hlth Org. techn. Rep. Ser.* 1951, 34, 28 (section 5.1.1, paragraph (1))

¹³ *World Hlth Org. techn. Rep. Ser.* 1951, 34, 29 (section 5.1.7, paragraph (2))

38. *Motor* (synonyms : power plant, engine). The prime mover which produces energy for the activation of the pump. (Applies to power sprayers.)

39. *Needle valve*. The hand-operated mechanism situated between the tank outlet and the burner nozzle which controls flow of liquid fuel to the burner. (Applies to flame sprayers.)

40. *Nozzle*. The device situated at the discharge end of the lance which reduces to a spray the liquid insecticide being forced out of the tank under pressure.

41. *Nozzle tip* (synonym : nozzle disc). That portion of the nozzle in which the spray orifice is situated.

42. *Plunger assembly* (synonym : piston assembly). A comprehensive term covering all the component parts comprising the plunger.

43. *Plunger shaft* (synonyms : pump shaft, plunger rod, plunger tube, piston rod). The member connecting the pump plunger to the handle. (This was referred to as a "plunger-rod" in the report on the second session.¹⁴)

44. *Plunger-shaft packing* (synonym : plunger-tube packing). A suitable chemical-resistant material used to form a liquid and air seal.

45. *Pressure gauge*. The device fitted to the sprayer unit which indicates the working pressure.

46. *Pressure range*. The pressure between the maximum and minimum working pressures.

47. *Pressure regulator* (synonyms : regulator, by-pass). The mechanism which maintains a pre-set pressure at its outlet despite variations in pressure at its inlet.

48. *Pump*. The apparatus used to compress air or liquid.

49. *Pump inlet* (synonyms : pump intake, pump inlet port). The base of the pump barrel supported by 3 or 4 crow feet which lift the pump clear of the bottom of the liquid container. This base is fitted with a strainer. (Applies to stirrup pumps.)

50. *Release valve* (synonym : exhaust valve). A manually operated valve for the release of air pressure.

51. *Relief valve* (synonym : safety valve). The automatic escape valve which releases air pressure when it exceeds a present amount.

52. *Spray boom* (synonyms : multiple jet lance, lance). A lance with multiple nozzles.

53. *Spray orifice* (synonym : spray aperture). The aperture in the nozzle tip.

¹⁴ *World Hlth Org. techn. Rep. Ser.* 1951, **34**, 29 (section 5.1.4, paragraph (2))

54. *Stirrup*. This comprises the barrel clamp, vertical bracket, and foot rest. (Applies to stirrup pumps.)

55. *Strainer* (synonyms: filter, screen). A screen for straining the insecticide as required. (This was referred to as a "filter" in the report on the second session.¹⁵)

56. *Strap* (synonyms: belt, carrying strap, harness, sling). The device for supporting the sprayer over the shoulder or on the back.

57. *Strap hanger* (synonym: sling hanger). The eyes or hooks, fixed to the body of the tank, onto which the strap is hooked or clipped.

58. *Tank* (synonyms: cylinder, container, reservoir). That part of the sprayer containing the insecticide. (This was referred to as a "cylinder" in the report on the second session.¹⁶)

59. *Tank bottom* (synonyms: base plate, cylinder bottom). The member comprising the bottom of the tank. (Applies to compression sprayers.) (This was referred to as a "base-plate" in the report on the second session.¹⁷)

60. *Tank top* (synonym: cylinder top). The member comprising the top of the tank containing the filler hole, pump, and other attachments. (Applies to compression sprayers.)

61. *Valve assembly*. A metal ball or other suitable-type valve fitted to the plunger shaft, or, in the case of the double-barrelled pump, in the base of the plunger barrel. (Applies to stirrup pumps.)

62. *Vertical bracket*. A metal rod to which is attached the foot rest and which is fitted to the pump barrel by the barrel clamp. (Applies to stirrup pumps only.)

63. *Wick*. The ignition mechanism to assure a continuous flame during operation of the burner. (Applies to flame sprayers.)

2. Specifications for Stirrup-Pump-Type Sprayers

There are two types of stirrup pumps—single- and double-barrelled—and the following specifications are applicable to both. Experience has shown that both units give satisfactory results. Specifications are given in general terms without exact measurements since satisfactory units of both types may have minor variations.

In general, the device shall be so designed that delivery will be as nearly uniform as possible over the entire operative cycle; the committee recom-

¹⁵ *World Hlth Org. techn. Rep. Ser.* 1951, 34, 28 (section 5.1.1, paragraph (2))

¹⁶ *World Hlth Org. techn. Rep. Ser.* 1951, 34, 28 (section 5.1.2)

¹⁷ *World Hlth Org. techn. Rep. Ser.* 1951, 34, 28 (section 5.1.2, paragraph (3))

mends that there shall be not more than 35% variation between maximum and minimum delivery under uniform operation.

All metals, gaskets, tubing, and other parts coming into contact with the spraying liquids shall be chemically resistant to them. The weight of the sprayer, complete with all auxiliaries, shall be not more than 3.18 kg (7 pounds) for single-barrel and 5.44 kg (12 pounds) for double-barrelled units.

2.1 Barrel

1. The barrel shall be smooth bore, with ability to withstand consistent rough usage in the field. It shall be capable of withstanding a pressure of the order of 13.6 atmospheres (atm.) (200 pounds per square inch (psi)) without distortion.

2. One end of the barrel shall be fitted with a heavy-duty, plunger-shaft housing-guide, and the other with a combined strainer assembly and foot valve.

3. In a single-barrel pump, the barrel shall be not more than 56 cm (22 inches) in length, and in a double-barrelled pump, not more than 20 cm (8 inches). The bore shall be not less than 1.8 cm ($\frac{7}{10}$ inch) nor more than 3.2 cm ($1\frac{1}{4}$ inch).

4. The pump inlet "crow feet" shall be sufficiently strong to withstand a crushing load of 68 kg (150 pounds) without damage.

2.2 Plunger assembly

1. The plunger assembly shall be capable of being easily removed for emergency field cleaning and repairs.

2. The plunger shaft shall be made highly torque-resistant. (See Annex 1, page 26.)

3. The pump handle shall be securely attached to the plunger shaft in such a manner that it will not tire the operator with unnecessary strain during the downward stroke of the piston. It shall be either "D"- or "T"-type and shall have a total length of not less than 15 cm (6 inches) available for the grip of the operator's hands. The handle may be of wood or metal.

4. A device shall be provided which will limit upward and downward travel of the plunger shaft within the barrel in order to avoid damage to either member (plunger shaft or barrel) at the end of its stroke. Sufficient overlap shall be provided within the barrel to maintain stability of the plunger shaft along its longitudinal axis.

5. The cup leather of the plunger assembly shall be of chrome leather impregnated with graphite and shall be a good fit within the barrel wall.

2.3 Valves

1. Valves shall be air- and liquid-tight.
2. The travel of the liquid inlet valve shall be limited by an appropriate stop.
3. A suitable valve shall be fixed at the intercommunicating aperture between the pump and air chamber in the case of double-barrelled pumps.
4. A relief valve opening at a pressure of 3.4 atm. (50 psi) shall be fitted either into the unit or near the attachment of the hose with the barrel.

2.4 Strainer

A strainer shall be provided at the inlet to the pump in the barrel base. The openings in this strainer shall have no dimension greater than 90% of the smallest dimension of the nozzle orifice. The total open area of the strainer shall be not less than 0.5 cm² (0.08 square inch). The strainer shall be mounted in such a way, or shall itself have sufficient structural strength, that it will not be subject to accidental puncture. The strainer shall be easily removable and replaceable.

2.5 Delivery outlet

The delivery-outlet hose-attachment shall be an adaptor about 2.5 cm (1 inch) long, screwed or welded to the unit.

2.6 Hose

1. The hose shall meet the specifications for this item described in section 4.1 of this report (page 19).
2. It shall not be less than 1 cm (³/₈ inch) inside diameter and shall be 3 m (10 feet) long, unless otherwise specified by the purchaser.

2.7 Lance

1. The lance shall be of rigid, seamless construction, and easily detachable for the purpose of cleaning.
2. The joint shall be leak-proof.

3. The lance shall be approximately 60 cm (2 feet) long. Extension lances, if specified, shall be of similar length and construction.

2.8 Cut-off valve

The cut-off valve shall meet the specifications for this item described in section 5 of this report (page 20).

2.9 Nozzle

The nozzle shall comply with the specifications for this item described in section 5.1.7, paragraph (1) of the report on the second session of the Expert Committee on Insecticides.¹⁸

2.10 Stirrup

1. The stirrup comprises the barrel clamp, vertical bracket, and foot rest.

2. The vertical bracket shall be made of mild steel of not less than 1.3 cm ($\frac{1}{2}$ inch) in diameter or of an alternative material of equal strength. The design shall be such that the vertical bracket can be readily clamped on the barrel and so that its height is adjustable. It shall be 6.3 cm ($2\frac{1}{2}$ inches) from the pump barrel and attached at right angles to the foot rest.

3. The foot rest shall not be less than 12.7 cm (5 inches) in diameter.

2.11 Plunger-shaft packing

The plunger-shaft packing shall be chemically resistant and so held in place that leakage of the liquid shall not occur under a pressure of 4.08 atm. (60 psi).

2.12 Liquid passages

No liquid passage within the unit may be less than 0.25 cm² (0.04 square inch) in cross-sectional area, exclusive of the nozzle.

¹⁸ *World Hlth Org. techn. Rep. Ser.* 1951, 34, 29

3. Specifications for Hand Dusting Apparatus

There are four general types of hand-operated dusters :

- (1) Hand-carried, hand-activated plunger
- (2) Hand-carried, hand-activated bellows
- (3) Shoulder- or back-carried, hand-activated plunger or bellows
- (4) Front-carried, hand-activated rotary.

The committee has prepared specifications for numbers (1) and (4). It did not consider that specifications for numbers (2) and (3) were necessary at the present time.

3.1 Hand-carried, hand-activated, plunger-type duster

3.1.1 *General*

1. All materials but the cup leather, handle, and shaft guide shall be of metal, and the unit shall be sufficiently robust to withstand severe field service.

2. All materials exposed to normal, dry, powdered insecticides and diluents shall be chemically resistant.

3. It is recommended that the duster shall be provided with a conveniently located, securely attached handle with a cylindrical-type grip formed to fit the hand. A shoulder strap shall be provided to facilitate carrying and ease of operation. This strap shall be about 3.8 cm ($1\frac{1}{2}$ inches) wide, 0.3 cm ($\frac{1}{8}$ inch) thick, and approximately 150 cm (60 inches) long, equipped with a means of ready adjustment.

3.1.2 *Pump*

3.1.2.1 *Barrel*

1. The barrel shall be approximately 15 cm to 30 cm (6 to 12 inches) long, with a diameter of approximately 5 cm to 10 cm (2 to 4 inches).

2. An adequate gravity oil-hole shall be provided through the barrel near the open end.

3.1.2.2 *Plunger assembly*

1. *Handle.* The "T" handle shall be approximately 10 cm (4 inches) long and 3.8 cm ($1\frac{1}{2}$ inches) deep at its junction with the plunger shaft, tapered to 2.5 cm (1 inch) at the end.

2. *Plunger shaft.* The plunger shaft shall have adequate strength to retain inflexibility in hard service. The cross-sectional measurement depends

largely upon the type of material used. It shall be joined to the "T" handle in a manner which will not tire the operator nor cause abrasions and blisters on his hand.

3. *Plunger-shaft guide.* This may consist of either wood or metal.

(a) Wooden guides shall be made of hard, well-seasoned material, cut so that the plunger shaft travels parallel to the grain if no metal bush is supplied, and shall be of sufficient length to reduce possible splitting and cracking. They shall be firmly joined to the plunger barrel by at least three screws of adequate size.

(b) Metal guides shall be sufficiently robust to withstand distortion.

(c) The entire plunger assembly shall be easily dismantled for quick servicing in the field.

4. *Cup leather.* This may consist of chrome leather, graphite-impregnated, or other equally durable material. It shall be a good fit in the barrel bore, with its lip not less than 1.3 cm ($\frac{1}{2}$ inch) deep on the barrel-bore face, thickness of not less than 2.25 mm (0.09 inch). A star or hexagonal spring-retainer shaped to fit within the cup leather shall be provided. This assists in the retention of the cup-leather shape and maintains uniform pressure between the cup leather and the barrel face.

5. *Cup-leather discs.* These are reinforcing units holding the cup leather in place and reducing possibility of distortion. The outer disc shall have a diameter slightly less than that of the inside diameter of the barrel and the inner disc shall fit the bore of the cup leather.

6. *Spring stops.* It is desirable that a spring stop be mounted above and below the cup assembly on the plunger shaft in order to reduce or eliminate wear due to plunger hammer, and to eliminate fatigue on the hand of the operator.

3.1.2.3 *Air valve*

1. The valve must close positively so that no dust may be drawn through it into the pump barrel on the inspiration stroke of the plunger.

2. It shall be protected from dust accumulation in order to prevent clogging.

3. It is recommended that the air-valve assembly shall be easily dismantled for cleaning and maintenance.

3.1.3 *Dust reservoir*

3.1.3.1 *Capacity*

Shall be 1,000 to 2,000 cm³ (60-120 cubic inches).

3.1.3.2 *Filler hole*

The diameter of the filler hole shall be not less than three-quarters of the diameter of the dust reservoir. In instances where the filler hole is on the circumference of the container, it shall be as large as feasible.

3.1.3.3 *Filler cap*

The filler cap shall be threaded and of leak-proof design.

3.1.3.4 *Discharge tube from reservoir*

1. This shall consist of a smooth-bore tube, securely attached to the reservoir, with a thickness of not less than 0.5 mm (0.02 inch), a length of about 5 cm (2 inches), and an internal diameter of 0.6 cm ($\frac{1}{4}$ inch) to 1.3 cm ($\frac{1}{2}$ inch). (The smaller size is recommended.)

2. Length of extension tubing of 15 cm (6 inches), 30 cm (12 inches), and 46 cm (18 inches) shall be provided with each unit.

3.1.3.5 *Discharge nozzles*

1. These shall be of metal not less than 0.5 mm (0.02 inch) in thickness.

2. A circular nozzle shall be provided with an aperture of approximately one-half the cross-sectional area of the discharge tube. It shall be bullet-nosed in shape to reduce sharp angles in which dust may tend to collect and pack.

3. A fan nozzle which will replace or fit over the circular nozzle shall also be provided.

3.1.3.6 *Agitator*

The agitator shall be so designed as to ensure violent agitation and complete discharge of all dust from the reservoir, but, at the same time, to prevent the ingress of powder into the air valve and clogging of the air agitator tube.

3.1.3.7 *Assembly*

The pump and dust reservoir shall be substantially joined in an air-tight manner.

3.2 Front-carried, hand-activated, rotary duster

3.2.1 *General*

3.2.1.1 *Basic design*

In this type of equipment, dust is ejected by a stream of air.

3.2.1.2 *Performance*

Delivery shall be continuous. The rate of delivery shall, however, be adjustable, and shall be capable of a maximum of at least 340 g (12 ounces) of dust¹⁹ per minute with the activating handle operated at not more than 35 revolutions or cycles per minute. Test of delivery shall be carried out as indicated in Annex 2, page 26.

3.2.1.3 *Weight*

The weight of the basic apparatus including the empty reservoir shall not be more than 6.8 kg (15 pounds).

3.2.2 *Materials*

The duster shall contain no wooden parts other than the handles. All materials exposed to the insecticide formulation shall be chemically resistant and sufficiently strong to withstand severe field service. Bearings and gears shall be of brass, bronze, steel, or other materials of equal durability.

3.2.3 *Duster body*

3.2.3.1 *Reservoir*

The dust reservoir shall have a dust capacity of not less than 1,875 cm³ (114 cubic inches). The filler hole shall be not less than 12.7 cm (5 inches) in its smallest horizontal dimension and shall be equipped with a tight-fitting cover with an easily operated locking device which will hold it securely closed during operation.

3.2.3.2 *Agitator*

A device shall be incorporated within the reservoir which shall keep the dust sufficiently agitated to assist continuous gravity feed to the dust

¹⁹ Dust used for all tests shall consist of hydrated lime containing not more than 5% moisture and suitably screened to ensure a grain size of not more than 5 μ in diameter.

exhaust port. Test of this mechanism shall be carried out as indicated in Annex 3, page 26.

3.2.3.3 *Feed-control mechanism*

A feed-control mechanism shall be provided which shall be fully adjustable from zero to maximum output. The device shall be controlled from the outside of the duster and shall require no special tools for its operation. An index pointer and scale of discharge shall be provided.

3.2.3.4 *Gear-box*

Gears shall be enclosed within a dust-proof housing.

3.2.3.5 *Discharge tube*

A discharge tube with an inside diameter of not less than 3.8 cm ($1\frac{1}{2}$ inches) shall be provided. This may be attached directly to the air-stream outlet, but shall be so coupled as to permit the movement of the tip through an arc of at least 120° . Each duster shall be supplied with not less than three sections of tube, each being not less than 36 cm (14 inches) nor more than 46 cm (18 inches) in length. Each section shall be equipped with a locking device so that it will not be accidentally disengaged during normal operations. The strength of all tubes shall be such that they will withstand severe field service without damage.

3.2.3.6 *Support*

The point of contact of the duster with the body of the operator shall be designed in such a manner as to provide reasonable comfort during extended periods of operation.

3.2.3.7 *Handles*

1. A properly shaped crank-handle of a size which shall not unduly tire the hand of the operator during extended operation shall be provided. It shall rotate freely on the crank pin.

2. A second handle, attached to the body of the duster, shall be provided to counteract the torque of the crank when grasped by the operator.

3.2.3.8 *Straps*

The duster shall be provided with a strap about 3.8 cm ($1\frac{1}{2}$ inches) wide, 0.3 cm ($\frac{1}{8}$ inch) thick, and about 150 cm (60 inches) long, with a means of ready adjustment.

3.2.3.9 *Crank*

The crank-handle shall extend not more than 40 cm (16 inches) from the body of the operator at its point of maximum distance. It shall be fitted to the right-hand side of the apparatus and shall function with a clockwise motion.

4. Specifications for Chemical-Resistant Materials

4.1 Specification for chemical-resistant, cotton-reinforced rubber hose²⁰

4.1.1 *General*

Hose covered by this specification shall include sizes (inside diameter) 6 mm to 13 mm ($\frac{1}{4}$ to $\frac{1}{2}$ inch).

4.1.2 *Materials*

4.1.2.1 *Rubber*

The tube and cover shall be made of synthetic rubber or a mixture of synthetic and natural rubber with not more than 35% of the latter permissible.

4.1.2.2 *Cotton*

Reinforcements shall be made of cotton duck or cotton yarn. The material shall be evenly and firmly woven and free from unsightly defects such as dirt, knots, and lumps, as well as from irregularities of twist.

4.1.2.3 *Tube and cover*

The tube and cover shall be smooth, free from pitting, and uniform in thickness.

4.1.3 *Construction*

4.1.3.1 *Type*

The hose shall consist of a rubber tube, reinforced with cotton duck and a rubber cover. The whole shall be vulcanized together.

²⁰ The committee is of the opinion that insufficient information is available at the present time to establish a specification for plastic hose. At the same time, however, it is aware of the potentialities of the material.

4.1.3.2 *Reinforcement*

Plies of cotton duck shall be applied on a bias of 45° with edges lapped at least 1.3 cm ($\frac{1}{2}$ inch) (not sewed), and shall be well frictioned on both sides with a rubber compound which shall firmly join the plies to the rubber tube and cover, and to each other.

4.1.3.3 *Physical requirements*

The hose shall meet or exceed the requirements stated in Annex 4, page 27.

4.1.4 *Testing*

1. The purchaser shall test an adequate number of random samples to satisfy himself that the article meets the specification.
2. Tests shall be carried out as indicated in Annex 5, page 28.

4.2 **Specification for chemical-resistant washers**

The committee was of the opinion that insufficient information is available for considering specifications for this item but recommends that such information be collected for consideration at a future session.

5. **Specifications for Cut-off Valves**

5.1 **General**

Several types of cut-off valves are available on the commercial market. Others are in process of development. These specifications are not intended to restrict purchase of any satisfactory type of valve but rather to set general standards.

5.2 **Materials**

5.2.1 *Metal parts*

All metal parts of the valve shall be of brass or aluminium, or of stainless steel which shall contain not less than 8% nickel.

5.2.2 *Gaskets*

All gaskets and other parts not made of metal shall be chemically resistant to the action of insecticide formulations.

5.3 Connexions

All valves shall be equipped with screw threads on the inlet and outlet ports. The outer surface of the valve adjacent to the screw threads shall have opposing flat, or hexagonal, faces to permit the use of a wrench on them. A bayonet type of connector may be supplied on one or both ends of the valve, but such units shall be removable and not constructed as an integral part of the valve body.

5.4 Maintenance

The valves shall be so constructed that inner and outer parts are readily accessible and replaceable without the use of special tools.

5.5 Design

5.5.1 *Liquid passages*

There shall be no liquid passages in the valve through which the entire liquid volume must pass that have cross-sectional areas of less than 0.25 cm² (0.04 square inch).

5.5.2 *Cut-off valve handle*

The handle shall be conveniently located on the valve to permit actuation by the hand. Pressures upon it shall be as follows :

5.5.2.1 *Lever movement*

The force required to move the handle on a lever-type valve from the closed to open positions should not require a torque of more than 200 inch-ounces (1.04 foot-pounds or 0.1438 kilogram-metres).

5.5.2.2 *Lateral movement*

Valves depending upon direct lateral movement for their actuation shall not require a force greater than 227 g (8 ounces) if such force is designed to be exerted by one thumb or finger. Where such force may be exerted by the entire hand, the force required shall not exceed 0.9 kg (2 pounds).

5.5.2.3 *Locking device*

A device to hold the handle in the open position shall be provided. It shall be readily locked or released from the locked position by the simple movement of one finger of the operator's hand.

5.5.2.4 *Shape*

The valve handle and all associated parts shall conveniently fit the operator's hand without discomfort.

5.5.3 *Tests*

It is recommended that, if feasible, durability tests be performed as indicated in Annex 6, page 30.

5.5.4 *Technical improvements*

The following technical improvement is recommended for probable inclusion in the specification at a later date :

5.5.4.1 *Drip-control valve*

A combination drip-control and cut-off valve with the cut-off situated at the nozzle instead of at the base of the lance has been developed and is commercially available. This type is considered a distinct advance in cut-off valve design, and its use is to be encouraged commensurate with further favourable usage and availability.

6. Specifications for Clamp-type Hose-Connexions

There are two common types of hose connexions—the clamp type and the ferrule type :

(1) Clamp type : holds the hose in place on the pipe or tubing by means of a band held in tension around the hose. It is readily repaired with simple hand-tools.

(2) Ferrule type : holds the hose on the pipe or tubing by means of a mechanically attached ferrule. It cannot be replaced in the field, is not considered satisfactory, and, therefore, is not recommended.

The following specification applies to hose connexions used with pressures not exceeding 10.2 atm. (150 psi) and hose not exceeding 1.8 cm ($\frac{7}{10}$ inch) in inside diameter.

6.1 Maintenance

No connexion which requires any special tool to remove or to replace it on the hose shall be deemed to have met this specification. No shellac, cement, or chemical binder shall be required to effect leak-proof connexions under this specification.

6.2 Terminal connexions

Threaded terminal connexions shall have finished, hexagonal faces, opposing flattened surfaces, or wings, to facilitate removal.

6.3 Strength

Hose connexions shall be deemed to have met strength requirements if they withstand a static hydraulic pressure test of 20.4 atm. (300 psi) for a period of 5 minutes without evidence of leakage or structural failure.

6.4 Damage to hose

Connexions shall not be deemed to have met this specification if, after five applications to the hose, the tube or cover is damaged sufficiently to interfere seriously with subsequent applications. The five applications shall be made in series with no extended period of time intervening.

6.5 Fastener

The hose shall be held in close contact with the connexion by a metal compression member on the outside surface. This member shall have a width of approximately the inside diameter of the hose, shall be constructed as one unit, and shall have no bolts, nuts, or screws which may be easily separated from it. The unit shall have no sharp edges or extended projections which may catch on clothing or other objects.

7. Specification Chart for Spraying Apparatus

The committee considered a specification chart for compression-type sprayers which provides an evaluation of commercially available equipment, based on the specifications for this item recommended in section 5.1 of the report on the second session of the Expert Committee on Insecticides.²¹ It is understood that the ratings of the equipment are to be compiled from information furnished by the manufacturers. A comparison of the attributes of a sprayer as listed on the chart with the specifications recommended by the committee will reveal whether or not a particular item complies with them. For the sake of convenience, however, a column has been included which gives the results of this evaluation in the form of a positive or negative statement relative to compliance. It is felt that

²¹ *World Hlth Org. techn. Rep. Ser.* 1951, **34**, 27

such a rating will be of inestimable value to prospective purchasers using the committee's specifications and will be a guide and an incentive to manufacturers to comply with these specifications.

It is recommended that the specification chart in its amended form, as given in Annex 7 (page 31), be adopted by WHO. It is also recommended that, if the Director-General has any reason to doubt the claims of any manufacturer relative to a particular product's meeting the specification, he take steps to confirm, through the members of the Expert Advisory Panel on Insecticides, whether or not the statements made by the manufacturer are correct.

8. Mechanically Operated Compressors for Compression Sprayers

Mechanically operated compressors for compression sprayers have been used for some years in a number of areas. There is an indication that the use of a mechanical compressor has a slight advantage over the conventional hand-pump sprayer. The method is not considered to be adaptable except under special conditions, principally in areas of high labour costs and where equipment and repair facilities are readily available at a reasonable cost, including competent mechanical services. Areas where such mechanized equipment is used should, furthermore, be accessible to transport. The committee recommends that a very careful study be given to this question by anyone contemplating its inauguration for the purpose of efficiency and economy.

In Annex 8 (page 35) information is presented on the use of compression sprayers charged with air by hand-pump and by mechanically operated compressors.

9. Suggestions for Future Discussions

The committee, after completing the agenda, felt that there were additional important phases of this problem which should be given further consideration. Some of the items which might be given attention by a future committee dealing with equipment are :

(1) A continuation of the study and acceptance of nomenclature for insecticide-dispersing equipment.

(2) Revision of specifications for spraying nozzles.

(3) Specification for indicated types of misting and thermo-aerosol apparatus.

(4) Standardization of testing methods for the performance of insecticide-dispersing equipment. (After discussion of the subject, M. Lemierre,

who had introduced it, was asked to present a manuscript on the problem for consideration by members of the Expert Advisory Panel on Insecticides prior to its inclusion on the agenda of a future meeting.)

VOTE OF THANKS

The members of the committee wished to have placed on record their very great appreciation for :

(1) the arrangements for the session made by the Chief, Technical Development Services, Communicable Disease Center (US Public Health Service), Savannah ;

(2) the courtesy and welcome extended them by the staff of the Communicable Disease Center ;

(3) the expert manner in which Dr. S. W. Simmons conducted the deliberations of the committee in his capacity as Chairman ;

(4) the efficient and speedy recording and reproduction of the proceedings by Miss Langford and the secretarial staff of the Communicable Disease Center ;

(5) the efforts made by the Secretary of the Expert Committee on Insecticides towards ensuring the success of the session.

Annex 1**TEST FOR STRENGTH OF STIRRUP-PUMP-TYPE
SPRAYER PLUNGER-SHAFT**

The plunger shaft, stripped of all its parts, shall be placed in a horizontal position and supported across two iron or steel rods 2.5 cm (1 inch) in diameter and 40 cm (16 inches) apart between centres. A load of 22 kg (48.5 pounds) shall be applied for not less than 5 minutes at a point on the upper side of the plunger shaft midway between the supports. After removal of the test load, there shall be no permanent deflection of the shaft.

Annex 2**TEST OF DELIVERY**

The reservoir shall be filled approximately three-quarters full with lime dust, as previously specified.¹ The entire duster, including any outlet tubes, shall be weighed to the nearest gram or ounce. The unit shall be fixed rigidly in place and then be operated continuously and uniformly at not more than the specified speed for a period of at least 2 minutes. The weight of the duster and the undischarged dust shall then be determined to the nearest gram or ounce. The total weight of the dust discharged shall be computed and the discharge per minute determined.

Annex 3**PERFORMANCE TEST FOR AGITATOR**

The dust reservoir shall be filled to three-quarters of its capacity with lime dust, as previously specified.¹ The duster shall be fixed rigidly in place and shall be operated continuously at a medium rate of application until dust is no longer delivered from the outlet tube. The duster shall be deemed to have met this specification if, upon completion of the test described above, not more than 13.1 cm³ ($\frac{4}{5}$ cubic inch) of dust remain in the reservoir.

¹ See footnote 19, page 17.

Annex 4

PHYSICAL REQUIREMENTS FOR HOSE

	Inside diameter of hose		Tested according to Annex 5, section
	6 mm (1/4 inch) *	9-13 mm (3/8-1/2 inch)	
Tolerance in inside diameter, plus or minus	0.4 mm (0.015 inch)	0.8 mm (0.03 inch)	1
Thickness			
Tube, minimum	1 mm (0.04 inch)	1 mm (0.04 inch)	2
Cover, minimum	0.5 mm (0.02 inch)	0.5 mm (0.02 inch)	
Fabric reinforcement plies, minimum	2	2	—
Tensile strength			
Initial	54.4 atm. (800 psi)	54.4 atm. (800 psi)	3
Decrease after ageing, %	35	35	4
Friction **			
Between tube and plies, minimum	3.6 kg (8 pounds)	3.6 kg (8 pounds)	5
Between plies, minimum	4.5 kg (10 pounds)	4.5 kg (10 pounds)	
Between plies and cover	3.6 kg (8 pounds)	3.6 kg (8 pounds)	
Decrease after immersion, %	50	50	5, 7
Hydrostatic pressure test ***			
Burst test before immersion, minimum	54.4 atm. (800 psi)	54.4 atm. (800 psi)	6
Burst test after immersion, minimum	20.4 atm. (300 psi)	20.4 atm. (300 psi)	6, 7
Swelling, after immersion, maximum %	30	30	7, 8

* The specifications in this column will apply to all hoses up to and including 8 mm (1/4 inch) inside diameter.

** The rate of separation shall be not greater than 2.5 cm (1 inch) per minute under the specified load.

*** Where the hose is purchased exclusively for use on compression hand-sprayers or other sprayers with similar operating pressures, a 50% reduction in hydrostatic pressure requirements is allowed.

Annex 5

TESTS FOR HOSE

1. *Tolerance, inside diameter*

This dimension should be measured by means of a barrel-type expanding feeler-gauge.

2. *Thickness*

This dimension shall be determined by means of a micrometer after carefully separating the cover and tube from the reinforcement by means of a sharp knife or razor.

3. *Tensile strength*

This test may be performed by attaching one end of the sample to a solid support and hanging from the lower end weights as follows :

$$W = P \left(\frac{\pi D^2}{4} - \frac{\pi d^2}{4} \right)$$

where :

W is the weight required in pounds

D is the outer diameter in inches

d is the inner diameter in inches

P is the tensile strength in psi.

4. *Ageing*

The sample to be tested shall be placed in an oven in which the temperature is maintained at $78^{\circ} \pm 1^{\circ}\text{C}$ ($172.4^{\circ} \pm 1.8^{\circ}\text{F}$). The sample shall be so suspended that it will not be in contact with any metal part of the oven. The sample shall be removed and subjected to appropriate tests after 48 ± 0.25 hours.

5. *Friction*

A cylindrical section, 2.5 cm (1 inch) in length, shall be cut from the hose sample. This section shall be placed upon a metal rod, the diameter of which is approximately 80% of the tube diameter.

A cut shall be made the full length of the cylindrical section. The depth of this cut will depend upon the test to be carried out, i.e., through (1) cover, (2) first ply of reinforcement, and (3) second ply of reinforcement. The cut plies shall be stripped (peeled, pared) back a sufficient distance to permit attachment of a proper clamp. The clamp shall securely bind the separated portion of the ply throughout its full length. Weights as indicated in Annex 4 shall be hung from the clamp. (See fig. 1.)

FIG. 1. FRICTION TEST FOR HOSE

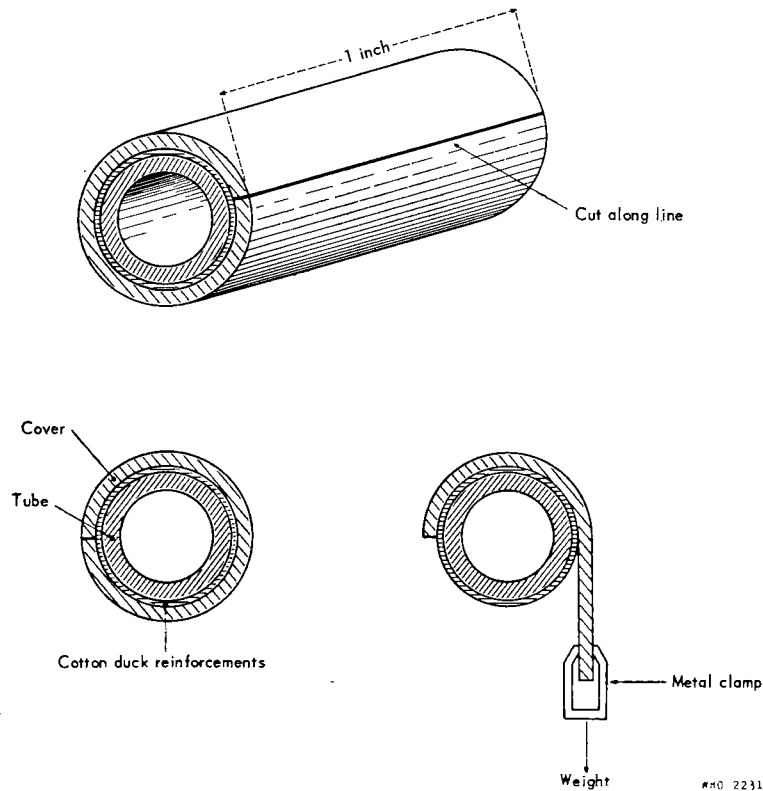

6. Hydrostatic pressure test

Samples of hose not less than 50 cm (20 inches) in length shall be coupled to a hydraulic pump. Water shall be pumped through the tube. While the tube is full of water, the open end shall be closed with a metal plug and secured with a compression clamp. The full indicated burst pressure shall be applied to the sample under test in a period of not more than 5 seconds.

7. *Immersion*

Where immersion is required, the sample shall be completely immersed in technical grade xylene. Care should be exercised to avoid formation of air pockets inside the tube and to keep the sample from contact with the surfaces of the container. The sample shall be left immersed for a period of 72 ± 0.25 hours at a temperature of 21° - 27° C (70° - 80° F). After completion of immersion, the sample shall be dried by hanging in air at $21^{\circ} \pm 6^{\circ}$ C ($70^{\circ} \pm 10^{\circ}$ F) for 24 hours.

8. *Swelling*

Swelling shall be determined by measuring the inside and outside diameters of the sample before and after immersion.

Annex 6

DURABILITY TESTS FOR CUT-OFF VALVES

Cut-off valves shall be tested under simulated natural conditions of operation. The valve shall be mounted on a test rack in such a manner that the body of the valve is held in a rigid position. A test fluid consisting of a 5% DDT-xylene emulsion shall be applied to the inlet of the valve under a static pressure of 3.4 atm. (50 psi). The outlet of the valve shall be carried through a spray nozzle designed to deliver 0.76 litre (0.2 US gallon) per minute under the stated pressure. The nozzle may discharge directly or through appropriate piping into a reservoir from which the emulsion is pumped back under pressure to the inlet port of the valve. Where such recycling is used, the emulsion shall be changed after each 48 hours of test. The testing apparatus shall be so arranged, by cams, solenoids, or other devices, that the valve mechanism will be actuated at a rate of not more than 15 cycles per minute. The mechanism shall open and close the valve in a period of not less than $\frac{1}{5}$ second nor more than $\frac{1}{2}$ second. Valves shall be deemed to have met this specification if, after 50,000 complete cycles of operation under the above conditions, there is no evidence of structural damage, deformation, or failure of the interior or exterior of the valve, and if no drip or leak through the valve or around the packing is evident during the entire test period.

The above tests shall be repeated with the input pressure to the valve at 6.8 atm. (100 psi) and the valve operated at this pressure for 500 cycles. The same criterion of acceptance shall apply to this latter test.

Annex 7

SPECIFICATION CHART
FOR COMPRESSION-TYPE SPRAYERS¹

- Column 1. *Materials of construction* : All metals, gaskets, and hose to be of chemical-resistant material.
- Column 2. *Strainers* : Two robustly constructed strainers shall be fitted—both readily removable.
- Column 3. *Strainer openings* : Openings to be one half of the micron dimension of the nozzle orifice.
- Column 4. *First strainer* : Shall be incorporated in the spray nozzle.
- Column 5. *Second strainer* : Shall be fitted in the interior of the tank, with an effective straining area of not less than 20 times that of the first strainer.
- Column 6. *Number of straps* : One or two adjustable straps to be provided.
- Column 7. *Size of straps* : Each to be 3.8 cm ($1\frac{1}{2}$ inches) wide, 0.3 cm ($\frac{1}{8}$ inch) thick, and 80 cm (32 inches) long, with provision for ready adjustment.
- Column 8. *Strap hangers* : Each tank shall be provided with two substantial strap hangers, the lower to be welded to the skirt and the upper to the top of the tank wall.
- Column 9. *Capacity* : The capacity of the tank shall be between 7.6 and 15.1 litres (2 to 4 US gallons)
- Column 10. *Weight* : The weight of the sprayer when empty shall not exceed 5.44 kg (12 pounds) complete with hose, belt, cut-off valve, lance, and nozzle.
- Column 11. *Tank pressure* : The tank shall be of the pre-pressurized type, tested to double the operating pressure.
- Column 12. *Tank construction* : The tank shall be seamless and of modern welded construction.
- Column 13. *Tank bottom* : The tank shall be fitted with a lipped tank bottom welded to the walls, and protected with an extension skirt 2.5 cm–3.8 cm (1 inch to $1\frac{1}{2}$ inches) deep and a rolled bottom edge.
- Column 14. *Tank markings* : The tank shall be clearly and permanently marked to indicate the recommended maximum liquid charge.

¹ The ratings on this specification chart have been compiled from information provided by manufacturers and catalogues issued by them.

Make and type	1 Materials	2 Strainers	3 Strainer openings	4 First strainer	5 Second strainer	6 Number of straps	7 Size of straps	8 Strap hangers	9 Capacity (gallons)	10 Weight (pounds)	11 Tank pressure	12 Tank construction	13 Tank bottom	14 Tank markings	15 Tank top	16 Filler hole
"A"	C	1	NS	C	N	1	C	N	4	11½	C	C	C	C	C	C
"B"	C	1	NS	C	N	1	C	N	4	11	C	C	C	C	C	C
"C"	C	1	NS	C	N	1	C	N	3½	10	C	C	C	C	C	C
"D"	C	1	NS	C	N	1	C	N	3½	9½	C	C	C	C	C	C
"E"	C	1	NS	C	N	1	C	N	2¾	9½	C	C	C	C	C	C
"F"	C	1	NS	C	N	1	C	N	3½	9½	C	C*	C	C	C	C
"G"	C	1	NS	C	N	1	C	N	3¼	8½	C	C*	C	C	C	C
"H"	C	2	C	C	C	1	C	C	3½	11	C	C	C	C	C	C

C = Complies with above specifications. N = Does not comply with above specifications.
* Funnel top. Pump is withdrawn with filler cap.

Column 15. *Tank top* : The tank top shall be of robust construction welded to the side walls.

Column 16. *Filler hole* : Shall not be less than the equivalent of 5 cm (2 inches) in diameter.

Column 17. *Pump construction* : The pump shall be of seamless construction.

Column 18. *Pump fitting* : The pump shall be easily detachable from the tank.

Column 19. *Plunger shaft* : The plunger shaft shall be of heavy-duty construction.

Column 20. *Pump handle* : The pump handle shall be of the "D" type.

Column 21. *Pump-handle locking-device* : The handle shall be fitted with a durable, quick action locking-device.

Column 22. *Pump barrel* : The pump barrel shall be capable of withstanding pressures of the order of 8.8 atm. (130 psi) without distortion.

Column 23. *Check valve* : The check valve shall be liquid- and air-tight.

17	18	19	20	21	22	23	24	25	26	27	28	29	30	31	32	33	
Pump construction	Pump fitting	Plunger shaft	Pump handle	Locking device	Pump barrel	Check valve	Nozzle spray	Spray angle	Nozzle discharge	Nozzle drip	Nozzle facing	Nozzle metal	Lance	Cut-off valve	Hose	Tank discharge outlet	Complies with the specifications recommended by the Expert Committee on Insecticides
C	C	C	C	C	NS	C	C **	NS	C	NS	C	C	C	NS	C	C	No
C	C	C	C	C	NS	C	C **	NS	C	NS	C	C	C	NS	C	C	No
C	C	C	C	C	NS	C	C **	NS	NS	NS	C	C	C	NS	C	C	No
C	C	C	C	C	NS	C	C **	NS	NS	NS	C	C	C	NS	C	C	No
C	C	C	C	C	NS	C	C **	NS	NS	NS	C	C	C	NS	C	C	No
C	C	C	C	C	NS	C	C **	NS	NS	NS	C	C	C	NS	C	C	No
C	C	C	C	C	C	C	C	C	C	C	C	C	C	C	C	C	Yes

NS = Not stated in maker's catalogue.

** Four interchangeable spray discs provided with sprayer : flat fan, solid or hollow cone, fine and coarse stream.

Column 24. *Nozzle spray* : The nozzle tip shall be capable of producing a flat spray of uniform pattern.

Column 25. *Spray angle* : The flat spray produced by the nozzle (column 24) should have a spray angle of 60°-65°.

Column 26. *Nozzle discharge* : The rate of discharge from the nozzle shall be between 0.76 litre (0.2 gallon) and 1.5 litre (0.4 gallon) per minute at 2.7 atm. (40 psi).

Column 27. *Nozzle drip permissible* : When continuously operated over a period of one minute at a pressure of between 2.0 atm. (30 psi) and 2.7 atm. (40 psi), the nozzle shall not produce dripping from the spray orifice at a rate in excess of 5 drops over the period of test.

Column 28. *Nozzle facing* : The nozzle shall have flat or hexagonal faces, to facilitate removal and replacement.

Column 29. *Metals to be used in the construction of nozzles* : Nozzles should be of stainless steel or of material of equivalent hardness and resistance to corrosion.

Column 30. *Lance* : Lances shall be of seamless construction and should be easily detachable and extendable. Joints should be leak-proof and effected by nuts with hexagonal or flattened faces.

Column 31. *Cut-off valve* : Shall be robust, easily manipulated with a positive, non-drip cut-off.

Column 32. *Hose* : Hose shall be chemical- and oil-resistant; length about 75 cm (30 inches); inside diameter 1 cm ($\frac{3}{8}$ inch); and shall be capable of withstanding maximum pump pressure.

Column 33. *Tank discharge outlet* : Shall be 1 cm ($\frac{3}{8}$ inch) in diameter, fitted to the wall of the tank.

Annex 8

**COMPARATIVE DATA ON EFFICIENCY
OF COMPRESSION SPRAYERS
UTILIZING MANUAL AND MECHANICAL COMPRESSION**

1. *Provided by the Communicable Disease Center (US Public Health Service), USA*

	Sprayers charged with hand pump	Sprayers charged with mechanical compressor
Labour,* man-minutes per house	35.88	34.99
Houses per day	9.788	9.994
Cost per application (US \$)	0.820	0.803

* One-man crew

Operations, upon which the time-motion studies were based, employed three types of compressors, as follows :

(1) A compressor, mounted on and driven by the vehicle engine, was manually controlled as to speed and length of operation when pressure was required.

(2) A compressor, mounted on the vehicle engine, was automatically controlled in such a manner that constant pressure was maintained in an air tank.

(3) A compressor, mounted adjacent to, and driven by, a small auxiliary gasoline engine, was manually started and controlled when pressure was needed in the air tank.

All compressors had capacities in the neighbourhood of 0.075 m³ (2.65 cubic feet) per minute of free air. All units were equipped with steel air tanks of approximately 114-litre (30-US-gallon) capacity, in which working pressures ranged from 5.1 atm. (75 psi) to 10.2 atm. (150 psi).

2. *Provided by the Division of Malariology, Ministry of Health and Social Welfare, Venezuela*

	Sprayers charged with hand pump	Sprayers charged with mechanical compressor
Squad No. 37 (the best)		
Litres per man-hour	25.4 (6.7 US gallons)	34.9 (9.2 US gallons)
Houses per man-month	168.8	229.0
Cost per house (bolivares) *	6.95	6.14
Average of other 8 squads		
Litres per man-hour	18.1 (4.8 US gallons)	21.5 (5.7 US gallons)
Houses per man-month	174.6	208.0
Cost per house (bolivares) *	6.32	6.03

* 1 bolivar equals US \$0.30

Squads were made up of one driver, who was the chief, and five workers who did actual spraying of houses.

Every squad was equipped with a 2.5-ton power wagon-truck on which a mechanically operated compressor with a 114-litre (30-US-gallon) tank, 10.2 atm. (150 psi) automatic cut-out pressure, 0.093 m³ (3.3 cubic feet) per minute free air, and 1¹/₄ HP standard-make gasoline engine were installed.

One or more extra compression sprayers, according to circumstances, were added to every squad's equipment in order that the driver could recharge while the rest of the squad was spraying. In this manner no time was lost by the workers in recharging their compression sprayers.