



PART III

Laboratory equipment

10. Biological safety cabinets

Biological safety cabinets (BSCs) are designed to protect the operator, the laboratory environment and work materials from exposure to infectious aerosols and splashes that may be generated when manipulating materials containing infectious agents, such as primary cultures, stocks and diagnostic specimens. Aerosol particles are created by any activity that imparts energy into a liquid or semiliquid material, such as shaking, pouring, stirring or dropping liquid onto a surface or into another liquid. Other laboratory activities, such as streaking agar plates, inoculating cell culture flasks with a pipette, using a multichannel pipette to dispense liquid suspensions of infectious agents into microculture plates, homogenizing and vortexing infectious materials, and centrifugation of infectious liquids, or working with animals, can generate infectious aerosols. Aerosol particles of less than 5 μm in diameter and small droplets of 5–100 μm in diameter are not visible to the naked eye. The laboratory worker is generally not aware that such particles are being generated and may be inhaled or may cross-contaminate work surface materials. BSCs, when properly used, have been shown to be highly effective in reducing laboratory-acquired infections and cross-contaminations of cultures due to aerosol exposures. BSCs also protect the environment.

Over the years the basic design of BSCs has undergone several modifications. A major change was the addition of a high-efficiency particulate air (HEPA) filter to the exhaust system. The HEPA filter traps 99.97% of particles of 0.3 μm in diameter and 99.99% of particles of greater or smaller size. This enables the HEPA filter to effectively trap all known infectious agents and ensure that only microbe-free exhaust air is discharged from the cabinet. A second design modification was to direct HEPA-filtered air over the work surface, providing protection of work surface materials from contamination. This feature is often referred to as product protection. These basic design concepts have led to the evolution of three classes of BSCs. The type of protection provided by each is set out in Table 8.

Note. Horizontal and vertical outflow cabinets (“clean-air work stations”) are **not** biological safety cabinets and should not be used as such.

Class I biological safety cabinet

Figure 6 provides a schematic diagram of a Class I BSC. Room air is drawn in through the front opening at a minimum velocity of 0.38 m/s, it passes over the work surface and is discharged from the cabinet through the exhaust duct. The directional flow of

Table 8. Selection of a biological safety cabinet (BSC), by type of protection needed

TYPE OF PROTECTION	BSC SELECTION
Personnel protection, microorganisms in Risk Groups 1–3	Class I, Class II, Class III
Personnel protection, microorganisms in Risk Group 4, glove-box laboratory	Class III
Personnel protection, microorganisms in Risk Group 4, suit laboratory	Class I, Class II
Product protection	Class II, Class III only if laminar flow included
Volatile radionuclide/chemical protection, minute amounts	Class IIB1, Class IIA2 vented to the outside
Volatile radionuclide/chemical protection	Class I, Class IIB2, Class III

air whisks aerosol particles that may be generated on the work surface away from the laboratory worker and into the exhaust duct. The front opening allows the operator’s arms to reach the work surface inside the cabinet while he or she observes the work surface through a glass window. The window can also be fully raised to provide access to the work surface for cleaning or other purposes.

The air from the cabinet is exhausted through a HEPA filter: (a) into the laboratory

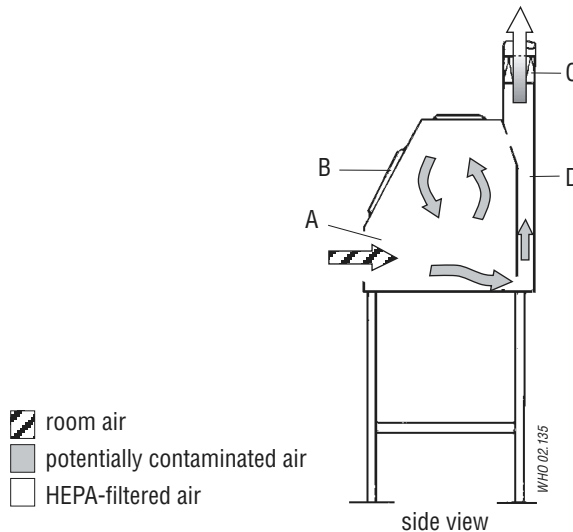

Figure 6. Schematic diagram of a Class I biological safety cabinet.
A, front opening; B, sash; C, exhaust HEPA filter; D, exhaust plenum.

and then to the outside of the building through the building exhaust; (b) to the outside through the building exhaust; or (c) directly to the outside. The HEPA filter may be located in the exhaust plenum of the BSC or in the building exhaust. Some Class I BSCs are equipped with an integral exhaust fan, whereas others rely on the exhaust fan in the building exhaust system.

The Class I BSC was the first recognized BSC and, because of its simple design, is still in wide use throughout the world. It has the advantage of providing personnel and environmental protection and can also be used for work with radionuclides and volatile toxic chemicals. Because unsterilized room air is drawn over the work surface through the front opening, it is not considered to provide consistently reliable product protection.

Class II biological safety cabinets

As the use of cell and tissue cultures for the propagation of viruses and other purposes grew, it was no longer considered satisfactory for unsterilized room air to pass over the work surface. The Class II BSC was designed not only to provide personnel protection but also to protect work surface materials from contaminated room air. Class II BSCs, of which there are four types (A1, A2, B1 and B2), differ from Class I BSCs by allowing only air from a HEPA-filtered (sterile) supply to flow over the work surface. The Class II BSC can be used for working with infectious agents in Risk Groups 2 and 3. Class II BSCs can be used for working with infectious agents in Risk Group 4 when positive-pressure suits are used.

Class II type A1 biological safety cabinet

The Class II type A1 BSC is shown in Figure 7. An internal fan draws room air (supply air) into the cabinet through the front opening and into the front intake grill. The inflow velocity of this air should be at least 0.38 m/s at the face of the front opening. The supply air then passes through a supply HEPA filter before flowing downwards over the work surface. As the air flows downwards it “splits” about 6–18 cm from the work surface, one half of the downwards flowing air passing through the front exhaust grill, and the other half passing through the rear exhaust grill. Any aerosol particles generated at the work surface are immediately captured in this downward airflow and passed through the front or rear exhaust grills, thereby providing the highest level of product protection. The air is then discharged through the rear plenum into the space between the supply and exhaust filters located at the top of the cabinet. Owing to the relative size of these filters, about 70% of the air recirculates through the supply HEPA filter back into the work zone; the remaining 30% passes through the exhaust filter into the room or to the outside.

Air from the Class IIA1 BSC exhaust can be recirculated to the room or discharged to the outside of the building through a thimble connection to a dedicated duct or through the building exhaust system.

Recirculating the exhaust air to the room has the advantage of lowering building

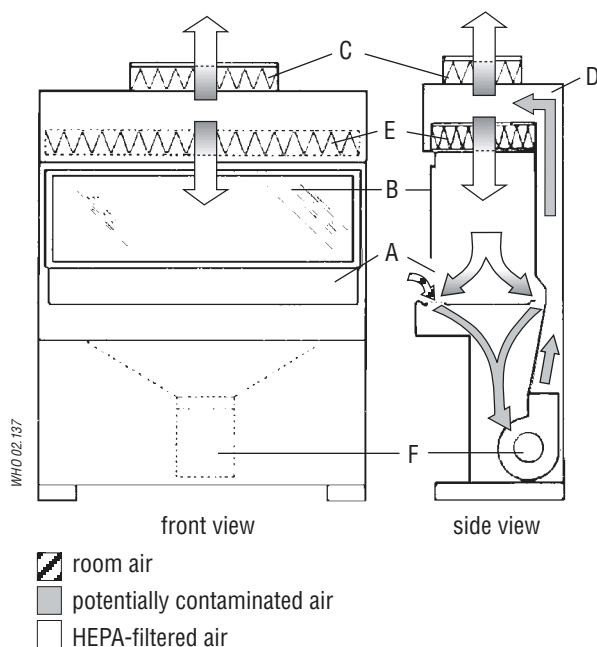

Figure 7. **Schematic representation of a Class IIA1 biological safety cabinet.**

A, front opening; B, sash; C, exhaust HEPA filter; D, rear plenum; E, supply HEPA filter; F, blower.

fuel costs because heated and/or cooled air is not being passed to the outside environment. A connection to a ducted exhaust system also allows some BSCs to be used for work with volatile radionuclides and volatile toxic chemicals (Table 8).

Class II type A2 vented to the outside, B1 and B2 biological safety cabinets

Class IIA2 vented to the outside, IIB1 (Figure 8) and IIB2 BSCs are variations of the type IIA1. Their characteristics, along with those of Class I and Class III BSCs, are indicated in Table 9. Each variation allows the BSC to be used for specialized purposes (see Table 8). These BSCs differ from one another in several aspects: the air intake velocity through the front opening; the amount of air recirculated over the work surface and exhausted from the cabinet; the exhaust system, which determines whether air from the cabinet is exhausted to the room, or to the outside, through a dedicated exhaust system or through the building exhaust; and the pressure arrangements (whether cabinets have biologically contaminated ducts and plenums under negative pressure, or have biological contaminated ducts and plenums surrounded by negative-pressure ducts and plenums).

Complete descriptions of the various Class IIA and IIB BSCs can be obtained from references (7) and (8), and from manufacturers' brochures.

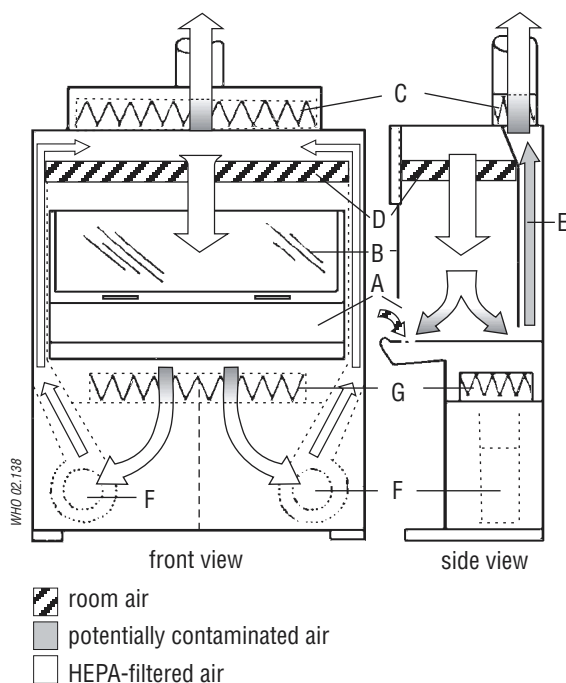

Figure 8. **Schematic diagram of a Class IIB1 biological safety cabinet.**

A, front opening; B, sash; C, exhaust HEPA filter; D, supply HEPA filter; E, negative-pressure exhaust plenum; F, blower; G, HEPA filter for supply air. Connection of the cabinet exhaust to the building exhaust air system is required.

Table 9. **Differences between Class I, II and III biological safety cabinets (BSCs)**

BSC	FACE VELOCITY (m/s)	AIRFLOW (%)		EXHAUST SYSTEM
		RECIRCULATED	EXHAUSTED	
Class I ^a	0.36	0	100	Hard duct
Class IIA1	0.38–0.51	70	30	Exhaust to room or thimble connection
Class IIA2 vented to the outside ^a	0.51	70	30	Exhaust to room or thimble connection
Class IIB1 ^a	0.51	30	70	Hard duct
Class IIB2 ^a	0.51	0	100	Hard duct
Class III ^a	NA	0	100	Hard duct

NA, not applicable.

^a All biologically contaminated ducts are under negative pressure or are surrounded by negative pressure ducts and plenums.

Class III biological safety cabinet

This type (Figure 9) provides the highest level of personnel protection and is used for Risk Group 4 agents. All penetrations are sealed “gas tight”. Supply air is HEPA-filtered and exhaust air passes through two HEPA filters. Airflow is maintained by a dedicated exhaust system exterior to the cabinet, which keeps the cabinet interior under negative pressure (about 124.5 Pa). Access to the work surface is by means of heavy duty rubber gloves, which are attached to ports in the cabinet. The Class III BSC should have an attached pass-through box that can be sterilized and is equipped with a HEPA-filtered exhaust. The Class III cabinet may be connected to a double-door autoclave used to decontaminate all materials entering or exiting the cabinet. Several glove boxes can be joined together to extend the work surface. Class III BSCs are suitable for work in Biosafety Level 3 and 4 laboratories.

Biological safety cabinet air connections

A “thimble” or “canopy hood” is designed for use with Class IIA1 and IIA2 vented to the outside BSCs. The thimble fits over the cabinet exhaust housing, sucking the cabinet exhaust air into the building exhaust ducts. A small opening, usually 2.5 cm in diameter,

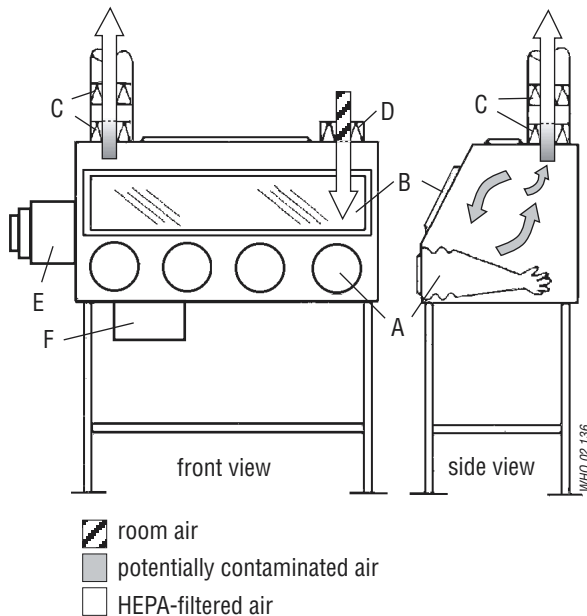

Figure 9. **Schematic representation of a Class III biological safety cabinet (glove box).** A, glove ports for arm-length gloves; B, sash; C, double-exhaust HEPA filters; D, supply HEPA filter; E, double-ended autoclave or pass-through box; F, chemical dunk tank. Connection of the cabinet exhaust to an independent building exhaust air system is required.

is maintained between the thimble and the cabinet exhaust housing. This small opening enables room air to be sucked into the building exhaust system as well. The building exhaust capacity must be sufficient to capture both room air and the cabinet exhaust. The thimble must be removable or be designed to allow for operational testing of the cabinet. Generally, the performance of a thimble-connected BSC is not affected much by fluctuations in the airflow of the building

Class IIB1 and IIB2 BSCs are hard-ducted, i.e. firmly connected without any openings, to the building exhaust system or, preferably, to a dedicated exhaust duct system. The building exhaust system must be precisely matched to the airflow requirements specified by the manufacturer for both volume and static pressure. Certification of hard-duct connected BSCs is more time-consuming than that for BSCs that recirculate air to the room or which are thimble-connected.

Selection of a biological safety cabinet

A BSC should be selected primarily in accordance with the type of protection needed: product protection; personnel protection against Risk Group 1–4 microorganisms; personnel protection against exposure to radionuclides and volatile toxic chemicals; or a combination of these. Table 8 shows which BSCs are recommended for each type of protection.

Volatile or toxic chemicals should not be used in BSCs that recirculate exhaust air to the room, i.e. Class I BSCs that are not ducted to building exhaust systems, or Class IIA1 or Class IIA2 cabinets. Class IIB1 BSCs are acceptable for work with minute amounts of volatile chemicals and radionuclides. A Class IIB2 BSC, also called a total exhaust cabinet, is necessary when significant amounts of radionuclides and volatile chemicals are expected to be used.

Using biological safety cabinets in the laboratory

Location

The velocity of air flowing through the front opening into a BSC is about 0.45 m/s. At this velocity the integrity of the directional air inflow is fragile and can be easily disrupted by air currents generated by people walking close to the BSC, open windows, air supply registers, and opening and shutting doors. Ideally, BSCs should be situated in a location remote from traffic and potentially disturbing air currents. Whenever possible a 30-cm clearance should be provided behind and on each side of the cabinet to allow easy access for maintenance. A clearance of 30–35 cm above the cabinet may be required to provide for accurate air velocity measurement across the exhaust filter and for exhaust filter changes.

Operators

If BSCs are not used properly, their protective benefits may be greatly diminished. Operators need to be careful to maintain the integrity of the front opening air inflow when moving their arms into and out of cabinets. Arms should be moved in and out

slowly, perpendicular to the front opening. Manipulations of materials within BSCs should be delayed for about 1 min after placing hands and arms inside to allow the cabinet to adjust and to “air sweep” the surface of the hands and arms. The number of movements across the front opening should also be minimized by placing all necessary items into the cabinet before beginning manipulations.

Material placement

The front intake grill of Class II BSCs must not be blocked with paper, equipment or other items. Materials to be placed inside the cabinet should be surface-decontaminated with 70% alcohol. Work may be performed on disinfectant-soaked absorbent towels to capture splatters and splashes. All materials should be placed as far back in the cabinet, towards the rear edge of the work surface, as practical without blocking the rear grill. Aerosol-generating equipment (e.g. mixers, centrifuges, etc.) should be placed towards the rear of the cabinet. Bulky items, such as biohazard bags, discard pipette trays and suction collection flasks should be placed to one side of the interior of the cabinet. Active work should flow from clean to contaminated areas across the work surface.

The autoclavable biohazard collection bag and pipette collection tray should not be placed outside the cabinet. The frequent in-and-out movement needed to use these containers is disruptive to the integrity of the cabinet’s air barrier, and can compromise both personnel and product protection.

Operation and maintenance

Most BSCs are designed to permit operation 24 h/day, and investigators find that continuous operation helps to control the levels of dust and particulate materials in the laboratory. Class IIA1 and IIA2 BSCs exhausting to the room or connected by thimble connections to dedicated exhaust ducts can be turned off when not in use. Other types such as IIB1 and IIB2 BSCs, which have hard-duct installations, must have airflow through them at all times to help maintain room air balance. Cabinets should be turned on at least 5 min before beginning work and after completion of work to allow the cabinet to “purge”, i.e. to allow time for contaminated air to be removed from the cabinet environment.

All repairs made on BSCs should be made by a qualified technician. Any malfunction in the operation of the BSC should be reported and repaired before the BSC is used again.

Ultraviolet lights

Ultraviolet lights are not required in BSCs. If they are used, they must be cleaned weekly to remove any dust and dirt that may block the germicidal effectiveness of the light. Ultraviolet light intensity should be checked when the cabinet is recertified to ensure that light emission is appropriate. Ultraviolet lights must be turned off while the room is occupied, to protect eyes and skin from inadvertent exposure.

Open flames

Open flames should be avoided in the near microbe-free environment created inside the BSC. They disrupt the airflow patterns and can be dangerous when volatile, flammable substances are also used. To sterilize bacteriological loops, microburners or electric “furnaces” are available and are preferable to open flames.

Spills

A copy of the laboratory’s protocol for handling spills should be posted, read and understood by everyone who uses the laboratory. When a spill of biohazardous material occurs within a BSC, clean-up should begin immediately, while the cabinet continues to operate. An effective disinfectant should be used and applied in a manner that minimizes the generation of aerosols. All materials that come into contact with the spilled agent should be disinfected and/or autoclaved.

Certification

The functional operation and integrity of each BSC should be certified to national or international performance standards at the time of installation and regularly thereafter by qualified technicians, according to the manufacturer’s instructions. Evaluation of the effectiveness of cabinet containment should include tests for cabinet integrity, HEPA filter leaks, downflow velocity profile, face velocity, negative pressure/ventilation rate, air-flow smoke pattern, and alarms and interlocks. Optional tests for electrical leaks, lighting intensity, ultraviolet light intensity, noise level and vibration may also be conducted. Special training, skills and equipment are required to perform these tests and it is highly recommended that they are undertaken by a qualified professional.

Cleaning and disinfection

All items within BSCs, including equipment, should be surface-decontaminated and removed from the cabinet when work is completed, since residual culture media may provide an opportunity for microbial growth.

The interior surfaces of BSCs should be decontaminated before and after each use. The work surfaces and interior walls should be wiped with a disinfectant that will kill any microorganisms that might be found inside the cabinet. At the end of the work day, the final surface decontamination should include a wipe-down of the work surface, the sides, back and interior of the glass. A solution of bleach or 70% alcohol should be used where effective for target organisms. A second wiping with sterile water is needed when a corrosive disinfectant, such as bleach, is used.

It is recommended that the cabinet is left running. If not, it should be run for 5 min in order to purge the atmosphere inside before it is switched off.

Decontamination

BSCs must be decontaminated before filter changes and before being moved. The most common decontamination method is by fumigation with formaldehyde gas. BSC decontamination should be performed by a qualified professional.

Personal protective equipment

Personal protective clothing should be worn whenever using a BSC. Laboratory coats are acceptable for work being performed at Biosafety Levels 1 and 2. A solid front, back-closing laboratory gown provides better protection and should be used at Biosafety Levels 3 and 4 (except for suit laboratories). Gloves should be pulled over the wrists of the gown rather than worn inside. Elasticized sleeves can be worn to protect the investigator's wrists. Masks and safety glasses may be required for some procedures.

Alarms

BSCs can be equipped with one of two kinds of alarm. Sash alarms are found only on cabinets with sliding sashes. The alarm signifies that the operator has moved the sash to an improper position. Corrective action for this type of alarm is returning the sash to the proper position. Airflow alarms indicate a disruption in the cabinet's normal airflow pattern. This represents an immediate danger to the operator or product. When an airflow alarm sounds, work should cease immediately and the laboratory supervisor should be notified. Manufacturers' instruction manuals should provide further details. Training in the use of BSCs should cover this aspect.

Supplementary information

Selecting the correct type of BSC, installing it, using it properly and annually certifying its operation are complex processes. It is highly recommended that they proceed under the supervision of a well-trained and experienced biosafety professional. The professional should be highly familiar with the relevant literature listed in the References section, and should have been trained on all aspects of BSCs. Operators should receive formal training in the operation and use of BSCs.

For further information see references (5) and (7–16), and Chapter 11.

11. Safety equipment

As aerosols are important sources of infection, care should be taken to reduce the extent of their formation and dispersion. Hazardous aerosols can be generated by many laboratory operations, e.g. blending, mixing, grinding, shaking, stirring, sonicating and centrifuging of infectious materials. Even when safe equipment is used, it is best to carry out these operations in an approved biological safety cabinet whenever possible. Biological safety cabinets and their use and testing are discussed in Chapter 10. The use of safety equipment is no assurance of protection unless the operator is trained and uses proper techniques. Equipment should be tested regularly to ensure its continued safe performance.

Table 10 provides a checklist of safety equipment designed to eliminate or reduce certain hazards and briefly outlines the safety features. Further details of much of this equipment are given in subsequent pages. Additional information on its proper use is provided in Chapter 12.

Information on equipment and operations that may create hazards is presented in Annex 4.

Negative-pressure flexible-film isolators

The negative-pressure flexible-film isolator is a self-contained primary containment device that provides maximum protection against hazardous biological materials. It may be mounted on a mobile stand. The workspace is totally enclosed in a transparent polyvinylchloride (PVC) envelope suspended from a steel framework. The isolator is maintained at an internal pressure lower than atmospheric pressure. Inlet air is passed through one HEPA filter and outlet air is passed through two HEPA filters, thus obviating the need to duct exhaust air outside the building. The isolator may be fitted with an incubator, microscope and other laboratory equipment, such as centrifuges, animal cages, heat blocks, etc. Material is introduced and removed from the isolator through supply and sample ports without compromising microbiological security. Manipulations are performed using gloved sleeves incorporating disposable gloves. A manometer is installed to monitor envelope pressure.

Flexible-film isolators are used to manipulate high-risk organisms (Risk Groups 3 or 4) in field work where it is not feasible or appropriate to install or maintain conventional biological safety cabinets.

Table 10. Biosafety equipment

EQUIPMENT	HAZARD CORRECTED	SAFETY FEATURES
Biological safety cabinet		
— Class I	Aerosol and spatter	<ul style="list-style-type: none"> • Minimum inward airflow (face velocity) at work access opening. Adequate filtration of exhaust air.
— Class II	Aerosol and spatter	<ul style="list-style-type: none"> • Does not provide product protection • Minimum inward airflow (face velocity) at work access opening. Adequate filtration of exhaust air
— Class III	Aerosol and spatter	<ul style="list-style-type: none"> • Provides product protection • Maximum containment • Provides product protection if laminar flow air is included
Negative pressure flexible-film isolator	Aerosol and spatter	<ul style="list-style-type: none"> • Maximum containment
Spatter shield	Spatter of chemicals	<ul style="list-style-type: none"> • Forms screen between operator and work
Pipetting aids	Hazards from pipetting by mouth, e.g. ingestion of pathogens, inhalation of aerosols produced by mouth suction on pipette, blowing out of liquid or dripping from pipette, contamination of suction end of pipette	<ul style="list-style-type: none"> • Ease of use • Controls contamination of suction end of pipette, protecting pipetting aid, user and vacuum line • Can be sterilized • Controls leakage from pipette tip
Loop microincinerators, disposable loops	Spatter from transfer loops	<ul style="list-style-type: none"> • Shielded in open-ended glass or ceramic tube. Heated by gas or electricity • Disposable, no heating necessary
Leakproof vessels for collection and transport of infectious materials for sterilization within a facility	Aerosols, spillage and leakage	<ul style="list-style-type: none"> • Leakproof construction with lid or cover • Durable • Autoclavable
Sharps disposal containers	Puncture wounds	<ul style="list-style-type: none"> • Autoclavable • Robust, puncture-proof
Transport containers between laboratories, institutions	Release of microorganisms	<ul style="list-style-type: none"> • Robust • Watertight primary and secondary containers to contain spills • Absorbent material to contain spills

EQUIPMENT	HAZARD CORRECTED	SAFETY FEATURES
Autoclaves, manual or automatic	Infectious material (made safe for disposal or reuse)	<ul style="list-style-type: none"> • Approved design • Effective heat sterilization
Screw-capped bottles	Aerosols and spillage	<ul style="list-style-type: none"> • Effective containment
Vacuum line protection	Contamination of laboratory vacuum system with aerosols and overflow fluids	<ul style="list-style-type: none"> • Cartridge-type filter prevents passage of aerosols (particle size 0.45 μm) • Overflow flask contains appropriate disinfectant. Rubber bulb may be used to close off vacuum automatically when storage flask is full • Entire unit autoclavable

Pipetting aids

A pipetting aid must always be used for pipetting procedures. Mouth pipetting must be strictly forbidden.

The importance of pipetting aids cannot be overemphasized. The most common hazards associated with pipetting procedures are the result of mouth suction. Oral aspiration and ingestion of hazardous materials have been responsible for many laboratory-associated infections.

Pathogens can also be transferred to the mouth if a contaminated finger is placed on the suction end of a pipette. A lesser known hazard of mouth pipetting is the inhalation of aerosols caused by suction. The cotton plug is not an efficient microbial filter at negative or positive pressure, and particles may be sucked through it. Violent suction may be applied when the plug is tightly packed, resulting in the aspiration of plug, aerosol and even liquid. The ingestion of pathogens is prevented by the use of pipetting aids.

Aerosols can also be generated when a liquid is dropped from a pipette on to a work surface, when cultures are mixed by alternate sucking and blowing, and when the last drop is blown out of a pipette. The inhalation of aerosols unavoidably generated during pipetting operations can be prevented by working in a biological safety cabinet.

Pipetting aids should be selected with care. Their design and use should not create an additional infectious hazard and they should be easy to sterilize and clean. Plugged (aerosol-resistant) pipette tips should be used when manipulating microorganisms and cell cultures.

Pipettes with cracked or chipped suction ends should not be used as they damage the seating seals of pipetting aids and so create a hazard.

Homogenizers, shakers, blenders and sonicators

Domestic (kitchen) homogenizers are not sealed and release aerosols. Only equipment designed for laboratory use should be used. Their construction minimizes or prevents

such release. Stomachers, which are now available for use with large and small volumes, may also produce aerosols.

Homogenizers used for Risk Group 3 microorganisms should always be loaded and reopened in biological safety cabinets.

Sonicators may release aerosols. They should be operated in biological safety cabinets or covered with shields during use. The shields and outsides of sonicators should be decontaminated after use.

Disposable transfer loops

The advantage of disposable transfer loops is that they do not have to be sterilized and can therefore be used in biological safety cabinets where Bunsen burners and microincinerators would disturb the airflow. These loops should be placed in disinfectant after use and discarded as contaminated waste (see Chapter 3).

Microincinerators

Gas- and electrically-heated microincinerators have borosilicate glass or ceramic shields that minimize the spatter and dispersal of infected material when transfer loops are sterilized. However, microincinerators can disturb the airflow and should therefore be placed towards the back of the work surface in biological safety cabinets.

Personal protective equipment and clothing

Personal protective equipment and clothing may act as a barrier to minimize the risk of exposure to aerosols, splashes and accidental inoculation. The clothing and equipment selected is dependent on the nature of the work performed. Protective clothing should be worn when working in the laboratory. Before leaving the laboratory, protective clothing should be removed, and hands should be washed. Table 11 summarizes some personal protective equipment used in laboratories and the protection afforded.

Laboratory coats, gowns, coveralls, aprons

Laboratory coats should preferably be fully buttoned. However, long-sleeved, back-opening gowns or coveralls give better protection than laboratory coats and are preferred in microbiology laboratories and when working at the biological safety cabinet. Aprons may be worn over laboratory coats or gowns where necessary to give further protection against spillage of chemicals or biological materials such as blood or culture fluids. Laundering services should be provided at/near the facility.

Laboratory coats, gowns, coveralls, or aprons should not be worn outside the laboratory areas.

Goggles, safety spectacles, face shields

The choice of equipment to protect the eyes and face from splashes and impacting objects will depend on the activity performed. Prescription or plain eye glasses can be

Table 11. Personal protective equipment

EQUIPMENT	HAZARD CORRECTED	SAFETY FEATURES
Laboratory coats, gowns, coveralls	Contamination of clothing	<ul style="list-style-type: none"> • Back opening • Cover street clothing
Plastic aprons	Contamination of clothing	<ul style="list-style-type: none"> • Waterproof
Footwear	Impact and splash	<ul style="list-style-type: none"> • Closed-toe
Goggles	Impact and splash	<ul style="list-style-type: none"> • Impact-resistant lenses (must be optically correct or worn over corrective eye glasses) • Side shields
Safety spectacles	Impact	<ul style="list-style-type: none"> • Impact-resistant lenses (must be optically correct) • Side shields
Face shields	Impact and splash	<ul style="list-style-type: none"> • Shield entire face • Easily removable in case of accident
Respirators	Inhalation of aerosols	<ul style="list-style-type: none"> • Designs available include single-use disposable; full-face or half-face air purifying; full-face or hooded powered air purifying (PAPR); and supplied air respirators
Gloves	Direct contact with microorganisms Cuts	<ul style="list-style-type: none"> • Disposable microbiologically approved latex, vinyl or nitrile • Hand protection • Mesh

manufactured with special frames that allow lenses to be placed in frame from the front, using shatterproof material either curved or fitted with side shields (safety glasses). Safety spectacles do not provide for adequate splash protection even when side shields are worn with them. Goggles for splash and impact protection should be worn over normal prescription eye glasses and contact lenses (which do not provide protection against biological or chemical hazards). Face shields (visors) are made of shatterproof plastic, fit over the face and are held in place by head straps or caps.

Goggles, safety spectacles, or face shields should not be worn outside the laboratory areas.

Respirators

Respiratory protection may be used when carrying out high-hazard procedures (e.g. cleaning up a spill of infectious material). The choice of respirator will depend on the type of hazard(s). Respirators are available with interchangeable filters for protection against gases, vapours, particulates and microorganisms. It is imperative that the filter is fitted in the correct type of respirator. To achieve optimal protection, respirators

should be individually fitted to the operator's face and tested. Fully self-contained respirators with an integral air supply provide full protection. Advice should be sought from a suitably qualified person, e.g. an occupational hygienist, for selection of the correct respirator. Surgical type masks are designed solely for patient protection and do not provide respiratory protection to workers. Some single-use disposable respirators (ISO 13.340.30) have been designed for protection against exposures to biological agents.

Respirators should not be worn outside the laboratory areas.

Gloves

Contamination of hands may occur when laboratory procedures are performed. Hands are also vulnerable to "sharps" injuries. Disposable microbiologically approved latex, vinyl or nitrile surgical-type gloves are used widely for general laboratory work, and for handling infectious agents and blood and body fluids. Reusable gloves may also be used but attention must be given to their correct washing, removal, cleaning and disinfection.

Gloves should be removed and hands thoroughly washed after handling infectious materials, working in a biological safety cabinet and before leaving the laboratory. Used disposable gloves should be discarded with infected laboratory wastes.

Allergic reactions such as dermatitis and immediate hypersensitivity have been reported in laboratory and other workers wearing latex gloves, particularly those with powder. Alternatives to powdered latex gloves should be available.

Stainless steel mesh gloves should be worn when there is a potential exposure to sharp instruments e.g. during postmortem examinations. Such gloves protect against slicing motion but do not protect against puncture injury.

Gloves should not be worn outside the laboratory areas.

For further information see references (12), (17) and (18).