

Rehabilitation for Persons With Traumatic Brain Injury

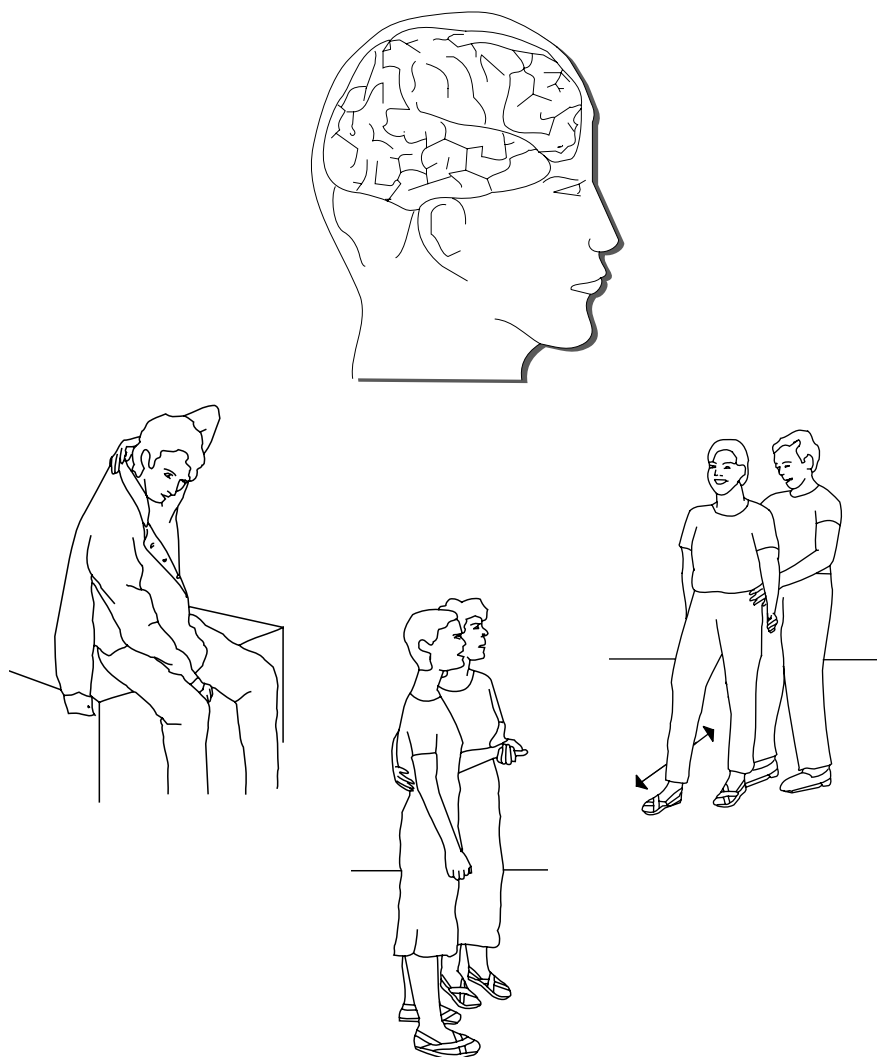

**World Health Organization
United States Department of Defense
Drucker Brain Injury Center,
MossRehab Hospital, USA**

2004

Abstract

This manual was developed as an educational and instructional tool for mid-level rehabilitation workers and primary health care personnel, to use in their work with persons who have sustained traumatic brain injury, their families and members of their communities.

Common medical, physical, cognitive and behavioral consequences of brain injury are reviewed. The manual emphasizes basic information for helping caregivers and community members, including teachers and potential employers, to better understand brain injury and to support an injured person's rehabilitation process.

Safety recommendations and care guides are provided, as well as training techniques for helping the person to relearn functional skills in mobility, communication and personal care. The writers recognize that specialized medical equipment is not always available, so suggestions are provided for using local materials to make devices to help prevent deformities and to assist persons with physical impairments in performance of everyday tasks.

Drawings are provided to help clarify safety guides, training instructions and the steps involved in making specific adaptive devices.

TABLE OF CONTENTS

FOREWARD	ii
PURPOSE OF THE MANUAL	1
1: Introduction	3
1.1 Basic Information About the Brain	3
1.2 What is Traumatic Brain Injury?	5
1.3 Prevention of Traumatic Brain Injury	6
2: Understanding Brain injury	8
2.1 Immediate Signs of Brain Injury	8
2.2 Medical Problems After Brain Injury	12
2.3 Changes in the Person That are Caused by Brain Injury	20
2.4 Helping the Person Learn and Perform Daily Activities	24
2.5 Helping the Person Manage Anger and Frustration	25
2.6 Sexuality and Relationships With a Partner After Brain Injury	26
3: Caring for the Person With Brain Injury at Home and in the Community	29
3.1 Guides for Safe Medical Care and Prevention of Injury	29
3.2 Information for Friends and Neighbors	34
4: Instructions for Helping People With Specific Problems Caused by Brain Injury	37
4.1 Unresponsiveness	37
4.2 Basic Care for the Person With Severe Brain Injury	41
4.3 Movement	48
4.4 Eating and Drinking	49
4.5 Washing and Bathing	60
4.6 Bowel and Urine Management	63
4.7 Dressing	65
4.8 Walking	72
4.9 Speaking	84
4.10 Reading and Writing	88
4.11 Homemaking	90
4.12 School Work	94
4.13 Rehabilitation for Work	99
Reference List	105

FOREWORD

Rehabilitation following a traumatic brain injury (TBI) is a complicated and challenging process for the person who was injured, the family, and all of the rehabilitation personnel who contribute to the process. In natural disasters and wars, where there may be many people with TBI, the request arises for a comprehensive approach to deal with the multiple disabilities each injured person experiences. Rehabilitation personnel working in developing countries have also requested information about a comprehensive approach for working with people with TBI.

This manual is a response to these requests. The manual is intended for people working in both general health care and rehabilitation services, in both emergency and routine services. It can be used for training personnel and as a guide when working with people with TBI. Personnel may also wish to give this manual to family members of people with TBI in order to help the families to understand the multiple limitations in function that may result from TBI, and to guide them in ways to help in the rehabilitation process.

We are extremely grateful to the people who recognized the need for this manual and took action to provide it. Mr Amit Pandya, as Director, Office of Humanitarian Assistance, United States Department of Defense (now Member of the Policy Planning Staff, Office of the Secretary of State, United States Government), lent much needed support at the United States Pentagon to secure the funding for this manual. Commander John C. Olsen, MD, as United States Navy Civil-Military Medical Policy Analyst, Office of Humanitarian Assistance, (now Medical Director, TRICARE Pacific Lead Agency, Honolulu, HI) provided much appreciated support in the conceptual, funding and editing stages of the manual's preparation. Dr John Melvin, current President of the International Federation of Physical Medicine and Rehabilitation, and Vice-President for Medical Affairs, MossRehab Hospital in Philadelphia, Pennsylvania, USA, kindly offered the services of his staff for the preparation of this manual. Dr Patricia Graham, in conjunction with the MossRehab Hospital staff, served as DoD-WHO Consultant-Liaison in the preparation of grant proposals and during the editing process.

Special recognition is due to Lynn Grahame, MSW, who contributed to and coordinated the preparation of the text and illustrations, and to the other authors:

Gary Goldberg, MD	Madeline DiPasquale, PhD
Tessa Hart, PhD	Mary Fran Madden, OTR/L
Gina Mancuso, LPT	Brenda Lennox, OTR/L
Heidi Weaver, OTR/L	Roberta Brooks, MA, CCC/SLP
Susan Robinson, MA, CCC/SLP	Sharon Menaldino, Ed D
Curry Baily, MS	Rosa Esquenazi, MFA, Illustrator
Ronald Kalstein, MEd	

We also thank Dr Ann Goerdt, former WHO staff member, who worked with the authors to guide the preparation of the manual so that it is comparable to other documents produced in collaboration with the Disability and Rehabilitation Team.



Dr Enrico Pupulin
Coordinator
Disability and Rehabilitation Team
World Health Organization
Geneva, Switzerland

PURPOSE OF THE MANUAL

The purpose of this manual is to assist the training of Mid-Level Rehabilitation Workers (MLRWs) and Primary Health Care Personnel (PHCP) who work with people who have experienced traumatic brain injury (TBI). After training, it is hoped that the manual will be a useful reference for review of medical and rehabilitation issues concerning persons with TBI and their caregivers.

The manual was prepared for primary health care personnel, (nurses, doctors and medical assistants) as well as rehabilitation workers because many types of personnel are needed in the brain injury rehabilitation process. The contents of this manual will help all health care personnel to understand the different types of disabilities that can result from traumatic brain injury, so that they may work more effectively with the individual person, the person's family and the community.

Traumatic brain injuries cause disabilities for men, women and children in all countries. Injuries are caused by road accidents, work-related accidents, violent acts, falls and accidents in sport or play activities. Sometimes there are additional causes, such as natural disasters, war or land mines.

In the past, little could be done to treat brain injuries and most severely injured people died. Today, improved medical procedures make it possible for more people to survive even the most severe brain injuries. However, survivors are often left with disabilities that affect their lives as well as the lives of their family members. Disabilities from brain injury include difficulties with movement, memory, thinking, communication and behavior.

Sometimes brain injury effects are clearly seen, such as when the person has obvious physical changes or difficulty with movement. However, many people with brain injury have disabilities that primarily relate to memory and thinking. Such persons may not be significantly changed in appearance or physical ability, so their disabilities may be much more difficult for the family and community to understand.

An important role for health care personnel is to help the person, family and community to understand all disabilities from brain injury, and to learn how to assist an injured person to recover as many abilities as possible.

This manual emphasizes that many people with TBI will need help from others for a very long time, perhaps for the rest of their lives. Nevertheless, with understanding, assistance and training, many people with TBI can return to useful roles and activities, including household responsibilities, school or work.

This manual has four sections. **Section 1** explains what happens to the brain when it is injured and also provides information on prevention of brain injuries.

Section 2 presents an overview of common medical, physical, cognitive and behavioral consequences of brain injury, including general guides for helping the person relearn functional skills. Because this manual is directed to Primary Health Care personnel as well as Mid-Level Rehabilitation Workers, this section includes information on the medical care that is often needed immediately following a brain injury.

Section 3 provides recommendations for the care and safety of the person at home and in the community. This includes information that can be given to people in the community so that they will better understand and support an injured person's rehabilitation process. Although health care personnel do not meet with community members to discuss individual situations, information can be given to involved families to share with their neighbors or with members of the larger community.

Section 4 is the longest section of the manual and presents detailed recommendations and descriptions of strategies and techniques for helping people relearn specific skills. These include skills needed for self-care, communication, ambulation and participation in homemaking, school and work activities.

Both men and women can have traumatic brain injuries so information in this manual alternates in gender reference and illustrations show both men and women.

Some readers may want additional general information about disabilities, to present to family members or others in the community. The manual concludes with a Reference List of other WHO materials that relate to the subjects presented in Rehabilitation for Persons With Traumatic Brain Injury.

1

INTRODUCTION TO REHABILITATION FOR PERSONS WITH TRAUMATIC BRAIN INJURY

1.1 Basic Information About the Brain

Understanding Traumatic Brain Injury begins with basic information about the brain. The brain is the control center for the entire body. It controls and directs all of the body's actions and functions. The brain is made up of four main areas:

The Brainstem. The brainstem connects the brain to the spinal cord. The brainstem directs the functions of our internal organs, including breathing, blood pressure and heart beat. The brainstem also controls our ability to be awake, alert and conscious.

The Cerebellum. The cerebellum controls and coordinates the way our muscles allow us to move and maintain our balance.

The Limbic System. The limbic system is a group of structures located deep in the brain. The limbic system controls our strongest emotions and our most basic human needs, such as food, water, sex, and self-protection.

The Cortex. The cortex is the area of the brain that controls our ability to gather information from the environment and use that information in everyday activities. The cortex is made up of four areas, called Lobes.

The Parietal Lobe controls our awareness of sensations such as touch, pain and temperature. It helps us to make sense our environment. The Parietal Lobe helps us to find our way from one place to another and it allows us to recognize the specific place, object or person we are seeking.

The Occipital Lobe takes in and interprets visual information. Our eyes see the world, but the Occipital Lobe allows us to interpret what we see.

The Temporal Lobe has much control over our ability to understand language and to communicate. The Temporal Lobe also enables memory for the information that we take in from the world around us.

The Frontal Lobe controls our emotions and our ability to behave appropriately with other people. It allows us to direct our thoughts and actions. The Frontal Lobe also controls much of our ability to direct the movements that we must make to perform the tasks of everyday life.

The Cortex is also divided into two halves called Hemispheres. The left half controls the right side of the body. The right half controls the left side of the body. In most people, the left hemisphere controls language. The right hemisphere enables us to pay attention and understand what is happening around us

The hemispheres divide the four lobes, with half of each lobe located in each hemisphere. These Right and Left parts of each Lobe have their own special areas of control. For example, in most people, the ability to speak, read and write is controlled in the Left Frontal Lobe.

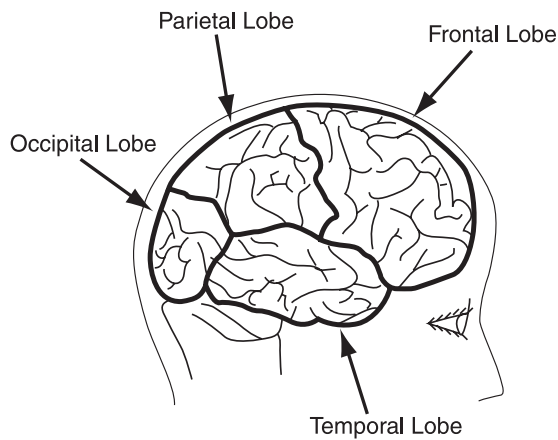

Fig. 1

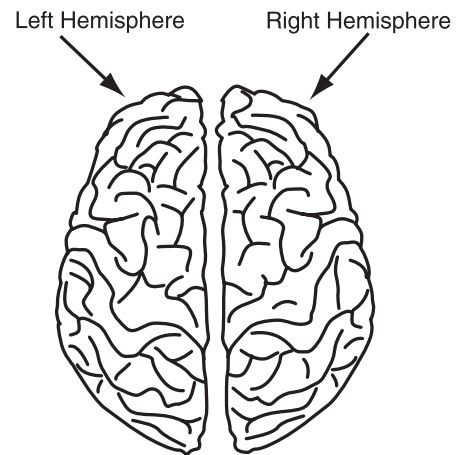

Fig. 2

1.2 What Is Traumatic Brain Injury?

Many events can cause brain injuries: a blow to the head, a fall, a bullet, a high-speed crash, or an explosion. There are two main types of traumatic brain injuries:

Open (penetrating) and Closed

OPEN BRAIN INJURY

In open brain injury, damage is caused by something that breaks the skull and penetrates the brain tissue. This can be a bullet or any sharp object. Brain tissue can also be penetrated by bits of bone that are broken during a fall or a blow to the skull.



Fig. 3

CLOSED BRAIN INJURY

In closed brain injury, the skull is not broken open and brain tissue is not penetrated, but the brain may still be severely injured. Although the skull is smooth on the outside, the inner surface of the skull bone is very rough. When there is rapid and forceful movement of the head, such as during a high-speed crash, the brain is twisted or shaken inside the skull. Fragile brain tissue can be stretched and broken as the brain twists. It can be bruised as the tissue hits against the rough surface of the skull bone. This can cause the brain to bleed and swell, even though the skull

remains unbroken. Tissue throughout the brain may be damaged or killed by brain movement inside the skull during the injury.

Closed brain injury may cause more numerous and more severe problems than open brain injury, because more of the brain's tissue may be damaged. Unlike some other body organs, the brain does not fully heal after it has been injured. For this reason, some of the effects of a traumatic brain injury will be permanent.

1.3 Prevention of Traumatic Brain Injury

It is important to educate people about the ways that brain injury can occur so that some injuries can be prevented. People who are aware of risks may give better attention to safety.

Information about brain injury prevention can be included in school health education programs. Posters can also be used to alert people to some of the common causes of brain injury and to what can be done to help prevent this injury. For men and women today, the most common causes of brain injury are:

VEHICLE CRASHES

Crashes of cars, trucks, motorcycles, bicycles and pedi-cabs cause many kinds of injuries to both riders and pedestrians. Cuts and broken bones that happen in such accidents usually heal but injury to the brain can be permanent.

Everyone should know about the importance of road safety. Seat belts, helmets and car seats can reduce the risk of serious injuries from a crash. There is less risk of injury when the vehicle driver obeys speed limits and passengers are secure inside the vehicle.

One of the most important rules for all vehicle operators is:

NEVER OPERATE A VEHICLE IF YOU ARE DRUNK OR UNDER THE INFLUENCE OF ILLEGAL DRUGS.

FALLS

Falls are a common cause of brain injury, especially when a person's head hits against the ground or against another hard object. Falls that can cause brain injury include: falls from a moving vehicle such as a bicycle or motor scooter, falls from stairs, ladders or poles, falls from trees, roofs or other high places, and falls from horses or other animals.

People who are unsteady on their feet, such as old people, young children and people who are sick or drunk, are at the greatest risk for falls. To reduce the risk of falls in the home, keep floors and stairways free of clutter and clean up water or other spills that may be slippery. It is also important to protect children by making their sleeping and play areas as safe as possible.

SPORTS INJURIES

Blows to the head are common in many sports, especially boxing, hockey and football. Sometimes an injury may appear to be very mild and the person may not even lose consciousness. He may feel pain or experience dizziness, confusion or blurred vision, but only for a short period of time.

A sports player, who experiences dizziness, blurred vision or memory loss after a blow to the head, should leave the game for at least the day. A player who continues to take blows to the head faces a risk that his many small injuries will eventually cause significant damage to his brain. All sports activities should be well supervised especially when children are involved.

VIOLENCE

Violent acts such as a shooting or a beating often cause brain injury. Violent shaking of adults or children to discipline or show anger can easily injure the brain. Land mines or other explosions may also result in brain injury for victims.

ACCIDENTAL GUNSHOT INJURY

Children may find and play with a gun that the family has bought for protection or for hunting. Guns and other weapons should always be kept in locked cabinets or other secure places.

2

UNDERSTANDING BRAIN INJURY

2.1 Immediate Signs of Brain Injury

The brain controls many different body functions. An injured brain may lose the ability to control some or all of these functions. Knowing some signs of brain injury can help to determine if a person has had a brain injury and how badly injured the brain may be. The information below describes what assistance should be given immediately to a person who has just had a brain injury.

2.1.1 Immediate Loss of Consciousness

A person with severe brain injury may not move at all and may appear to be sleeping. A person with a normal brain can easily be awakened from sleep by shaking him, pinching him, or by yelling his name or making a loud sound. Once awake, a person with a normal brain has little difficulty staying awake. A person with severe brain injury may wake up for a few seconds but then quickly fall back asleep. Or he may appear to be deeply asleep and will not awaken, no matter what is tried. The person who cannot be awakened is considered to be unconscious or in a coma. A state of coma means the brain injury is very severe.

2.1.2 Problems With Breathing

Immediately after a severe brain injury, a person is usually unconscious and may not be able to breathe on his own. If the person is unable to breathe for more than a few minutes, the brain will have additional injury from loss of oxygen. Prolonged loss of oxygen is a major cause of death following brain injury.

A common reason that an unconscious person is not breathing is because his tongue has fallen against the back of his throat and is blocking the opening to the trachea (windpipe). To move the tongue so that it no longer blocks the flow of air, place two fingers under each side of the person's chin and gently push the chin straight up. This action will lift the tongue up and away from the back of the throat.

Vomit or mucous in the mouth can also block the flow of air. Check the person's mouth and wipe out any vomit or mucous that is blocking the airway. PROTECT YOURSELF IF THE PERSON IS BLEEDING from the mouth or elsewhere. You want to avoid the risk of HIV from his blood splashing into your own eyes, nose or mouth.

If a non-breathing person is not bleeding in or around the mouth, Rescue Breathing may be tried with minimal risk of HIV infection.

1. Shout for any other person in the area to go and get help from a person with medical training.
2. Make sure the person's mouth is clear of food or vomit.
3. Place yourself beside his head, looking down toward his chest.
4. Gently position his head and neck in a straight line with his back.
5. Place one hand on his forehead and with your other hand pinch his nose shut.
6. Fully cover his mouth with your mouth and give one steady, full breath.
7. Allow the air to breathe out naturally.
8. Look, listen and feel for signs that the person is breathing on his own.

Rescue Breathing may help an unconscious person to begin again to breathe. However, many such severely injured persons will only survive if they have immediate emergency lifesaving procedures to maintain circulation of the blood or pump oxygen into the lungs. Training in emergency lifesaving procedures is often available through hospitals, clinics and organizations such as the American Red Cross.

*****Warning: a person who is unconscious may also have injury to the spinal cord. The spinal cord is a column of nerve fibers in the center of the spine (back bone) that starts at the bottom of the brain and ends at the lower back. The brain sends messages to the muscles through the nerves of the spinal cord. If the spinal cord is badly injured, the person may become partly or completely paralyzed.***

MEDICAL GUIDELINES RECOMMEND AGAINST MOVING AN INJURED PERSON UNTIL A TRAINED DOCTOR, NURSE OR MEDICAL ASSISTANT COMES TO THE ACCIDENT SCENE AND SAFELY POSITIONS THE PERSON'S HEAD AND NECK TO REDUCE THE RISK OF SPINAL CORD INJURY.

However, if a person is vomiting or bleeding from the mouth, it may be necessary to quickly re-position him so that vomit or blood flows out and does not cause him to choke. This is called the RECOVERY POSITION.

1. Gently move the person onto his side, with his head turned toward you and tilted forward to keep the airway open.
2. Bend the upper arm at a right angle to support the upper body.
3. Bend the upper leg at a right angle to support the lower body.

If you cannot wait for an ambulance, the following recommendations may help reduce the risk of additional injury to the spinal cord during transport to a medical center:

1. With the person lying flat on his back, slide a wooden board or a sheet of rigid metal or hard plastic under his body. Keep his head and neck in line with his spine (back bone) and move the head and neck as little as possible.
2. Place rolled towels, blankets or sandbags along each side of his head, neck and trunk. Place an additional roll of blanket or towel under the chin to prevent the chin from moving downward.
3. Secure the person and the blanket rolls or sandbags to the transport board by means of belts or ropes, so that his body is as motionless as possible during transport.

2.1.3 Identifying Level of Consciousness

Many hospitals and medical care providers throughout the world use the Glasgow Coma Scale as a way of measuring the injured person's level of awareness or coma. The following questions can be asked to help identify the level of consciousness or unconsciousness in a person who has just been injured:

Questions about Eye opening

- Are his eyes open? If the eyes are open, do they move?
- Does he appear to look at things around him? Does he follow movement with his eyes?
- Does he open his eyes if you shout his name or make a loud sound?

Questions about Movement

- Is he moving any part of his body?
- If not, does he move only when you pinch him?

- Does he try to pull away only the same part of the body you are pinching, or do all of his limbs move together no matter which one you are pinching?
- Can he move correctly if you ask him to move an arm or a leg? For example, can he lift up the right arm when you say "raise your right arm"? Can he squeeze your hand in his hand when you say "squeeze my hand"?

2.1.4 Gradual Loss of Consciousness

A person with severe brain injury may not immediately lose consciousness. He may remain awake for a short period of time after the injury and then gradually appear to fall asleep. A person should be regularly checked for the first day or two after an injury, to assure that he is able to awaken from sleep. Get immediate medical help for anyone who has had a recent injury to the head and is not able to awaken from sleep. A gradual loss of consciousness may mean that there is dangerous bleeding inside the skull.

2.1.5 Concussion Injury

A concussion is a brain injury that may cause only a brief loss of consciousness, or there may be no loss of consciousness at all. However, immediately after the injury, the person with concussion injury will display some degree of confusion and will usually have some brief loss of memory. Most people who experience a concussion will recover fully and have no long-lasting mental or physical difficulties, but some concussions are more serious. *The injured person should be asked the following questions to determine how serious the concussion may be:*

- Does he know his own name?
- Does he know where he is?
- Can he correctly tell you the month, day of the week, year and time?
- Can he remember anything about what happened to him?

Ask him to remember three things around him:

- Can he repeat them immediately? Can he repeat them after five minutes have passed?

It is especially important to get immediate medical attention for the person who cannot answer the questions correctly. His injury could be

very serious. After a concussion, even if a person is able to think clearly and answer the questions correctly, he may have the following difficulties for days, weeks or months:

- Feel constantly tired
- Have trouble sleeping at night
- Feel dizzy and lose balance
- Complain of headache or nausea
- Have problems with seeing, hearing, feeling or smelling
- Complain that light hurts his eyes
- Not be able to speak clearly
- Not understand what others are saying to him
- Become easily upset or angered
- Have trouble concentrating

Special Concerns for a Person Who Has Had a Concussion

A person who has had a concussion should be protected from having another concussion soon after the first one. Concussion causes brain swelling and the brain requires a few days to two weeks for swelling to decrease. All vigorous work or sports activities that could cause a fall or a blow to the head should be avoided during this time.

See 1.3 SPORTS INJURIES for more information regarding prevention of sports injuries.

2.2 Medical Problems After Brain Injury

Brain injury can cause medical problems with other body organs. These problems can be painful or can make the injured person very ill. All of the following problems require treatment from a doctor or nurse.

2.2.1 Fits

(also called Seizures)

A fit or seizure is an episode of abnormal movements that a person is not able to control. Fits happen when the transmission of messages from the brain to the muscles is disrupted by injured brain tissue, or when messages from injured brain tissue disrupt normal brain function.

Fits most often happen in the first few weeks after the injury. Open brain injuries (such as when a bullet goes through the skull and into the brain) are more likely to cause fits than closed brain injuries.

There are different types of fits. One type affects the entire body and usually lasts from one to five minutes. (A fit that lasts longer is especially serious and needs immediate medical attention.) The person may cry out, become unconscious and fall. Muscles of the arms and legs may stiffen and then have jerking movements. The person may stop breathing for a few seconds. She may lose control of her bladder or bowels. After the fit is over, she may act confused. Her speech may be slurred and she may complain of a headache. She may vomit.

Another common type of fit does not include jerking movements. Instead, the person suddenly stops talking or moving and stares. During the episode, her eyes are open but she does not have awareness of what is happening around her. This type of fit usually lasts for only a few seconds.

Doctors cannot predict if a person will have fits after brain injury. Some persons have one fit or only a few fits during the first weeks after the injury, and after that time they have no more fits. Some persons with brain injury have fits very often and the fits continue for the rest of their lives. Other persons have no fits immediately after the injury but then begin to have fits many years later.

First Aid for Fits:

Protect the person from injury. Help her to the ground. Put something soft under her head. Do not try to hold her still. Do not put anything into her mouth. If possible, turn her on her side to improve breathing and help any vomited material to drain out of her mouth. Call for help if the jerking of arms and legs lasts longer than five minutes.

Fig. 4

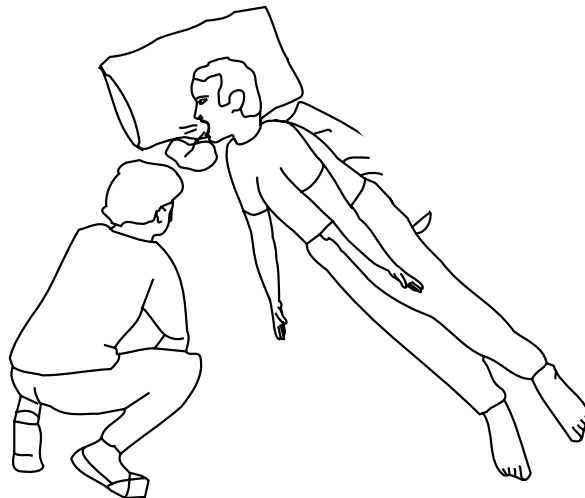

Medicines May Help Control Fits:

There are many medicines that can be used to help control fits. The person's doctor will need to decide if she should be given one of these medicines because the medicines can cause other problems such as drowsiness, skin rashes and dulled thinking. The doctor will also have to decide which medicine is likely to work best and may also have to try different doses of the medicine in order to control the person's fits.

Fits may happen even if the person is regularly taking medicine to prevent them. Some things that can increase a person's chance of having fits are:

- Fever, such as when the person has a cold or flu
- Drinking alcohol
- Flashing lights such as video games
- Menstruation

Safety Precautions for the Person With Fits:

Fits are not life threatening unless they continue beyond five minutes. However, fits can put the person at risk of having additional injury. The most common risk is that she may be injured when the fit causes a fall. Additional injury can also happen if the person has a fit while driving a vehicle or operating machinery. It is important to consider what safety precautions are needed in each individual case.

2.2.2 Increased Fluid in the Brain

(also called Post-Traumatic Hydrocephalus)

It is normal to have some fluid flowing around and through the brain. However, a dangerous problem can occur if too much fluid develops. In some persons with brain injury, a blockage forms inside the brain that causes a gradual buildup of excess fluid. When this happens, an injured person who has been recovering begins to show new problems. She may seem sleepy all the time. She may vomit. She may become confused. She may show more difficulty in walking or keeping balance. She may not be able to control her urine or feces.

A person with new problems needs medical attention to find out if she is developing excess fluid in the brain. She may need to have a special tube, called a shunt, placed into her brain by a brain surgeon. A shunt allows fluid that has built up inside the brain to flow out of the brain and down into the belly. After the shunt is in place, the person will often begin to get much better. Unfortunately, a shunt sometimes may block up or become infected. If that happens, the person will start to get worse again and the shunt will need to be replaced.

2.2.3 Flushing and Sweating *(also called Dysautonomia)*

Sometimes injury affects the way that the brain controls body temperature. The person may have a fever even though she is not actually sick. She may become agitated. She may be flushed and sweat heavily. Medicine may be needed to help control the flushing and sweating. Only a doctor will be able to decide what treatment will be helpful for this problem.

2.2.4 Lung Problems

Severe brain injury may cause a person to have difficulty with breathing, coughing and swallowing. If the person is not able to move out of bed or to breathe very deeply, she may not be able to cough up the sticky fluid (phlegm) that forms in her throat and lungs. This fluid can build up in her lungs and block movement of air in and out of the lungs, so that she breathes even more weakly. This condition is called pneumonia. Pneumonia is a very dangerous illness and requires immediate medical attention.

Moving the patient out of bed will help stimulate breathing and coughing. Sitting upright in a chair will help her to breathe more deeply and will help to move the fluid in her lungs. Sitting up or being moved in bed may help her to cough more easily. Coughing will help bring fluid out of the lungs so she can breathe more easily and have less risk of pneumonia.

The person may also develop lung problems if drink or food bits go into the windpipe and then into the lungs. The brain controls the muscles of the throat that allow a person to safely swallow food or drink. A person with a normal brain will cough when food or drink is swallowed the wrong way. A person with brain injury may not feel the wrong movement into the windpipe. The food or drink can pass from the windpipe into the lungs and block the air in the lungs. It can also cause infection in the lungs and the person will get pneumonia.

2.2.5 Problems With Taking Water and Food

All people must take food and water into their bodies in order to survive. A person with brain injury may need extra food because her body is working very hard to heal. If she does not receive enough food, she will start to lose weight. She may not be able to take in enough food if she is not able to swallow properly. Or she may not eat enough because she is too tired or her muscles are weak.

She may also have difficulty drinking water safely. Water that is not swallowed safely can go into the lungs and cause an infection (pneumonia). Problems can also result if she is not given enough water. Without enough water, a person will become weak and confused and may develop infection in the bladder or kidneys. Lack of enough water will cause her lips and tongue to become very dry, and her skin will appear soft and wrinkled.

A person with brain injury so severe that she cannot swallow safely may need to take her food and water by means of a tube that leads into the stomach. Some injured people need to be fed by tube for only a few weeks. For that person, a feeding tube can be passed through the nose, down the throat and into the muscular tube (esophagus) that goes from the mouth down to the stomach. However, after a period of time this type of feeding tube can cause problems inside the nose and in the throat. When swallowing problems last longer than a few weeks, a special tube may need to be inserted through the skin of the belly so that it passes directly into the stomach or into the small bowel. Only a trained doctor can insert this tube.

Special liquid food must be used with both of these types of feeding tubes. The proper amount of water must be boiled and cooled, and then combined with the liquid food each day to give the person just the right amount of food and water.

A person can be fed with a "stomach tube" for a long time. The tube is made of rubber and must be replaced with a new tube every few months. Some tubes have a small balloon on the tip that can be inflated with a small amount of water. This helps keep the tube in proper position and prevents it from sliding out of the belly.

Family members can be trained to give water and food by tube. They must also be trained to care for the skin around the tube and to replace the tube correctly in the person's stomach if it falls out.

Sometimes the tube will become blocked with dried food or fluids from the stomach. When this happens, water that has been boiled and cooled will need to be squirted into the tube to loosen the material that is blocking the tube. Bottled carbonated water or carbonated drinks such as cola or ginger ale can also be used to clean a clogged feeding tube.

2.2.6 Problems With Managing Urine and Feces

Urine and feces are formed in the body every day and are stored in special hollow inner parts of the body (the bladder for urine and the bowel for feces). As children, all persons learn to control the release of urine and feces, to do this in privacy and to use a toilet or a latrine. Unfortunately, a person with brain injury may have many kinds of

difficulties that prevent her from being able to manage her urine or feces by herself. The following are examples:

The very severely injured person's brain often does not direct the muscles of the bladder or bowel to release urine or feces. A build up of urine or feces can cause her to become very sick. It may be necessary to insert a tube (catheter) into her bladder to help her to release urine. A helping person may need to regularly give her a rectal suppository or enema to help the bowel release feces. A nurse or doctor may also train family members in other procedures to help the person pass urine or feces. Family members who care for a person with severe brain injury will need to ***make sure that she releases urine several times each day, and that she releases feces at least every other day.***

A severely injured person may be conscious but not know that she needs to use the toilet because she does not feel the sensation that her bladder or bowel is full. This person may need medicine or a suppository or enema to help her release her feces. She may need a diaper to catch her urine or feces.

For other persons, the muscles of the bladder and bowel are able to work correctly, but she soils herself because she does not feel when release is ready to happen. This person will need to be taken to the toilet every few hours, whether she feels a need or not. A regular routine of being placed on the toilet at the same times each day may help to retrain her bladder and bowel muscles.

A brain injury sometimes causes a person to lose awareness that she is expected to use a toilet or latrine. Or she may mistake other furniture or other places in the home for the toilet site. This person should be taken to the toilet every few hours, to help her to relearn the routine of using only the toilet or latrine when she needs to empty her bladder or bowels.

Sometimes the person is very aware of her body sensations and has the desire to empty her bladder and bowel in an acceptable way, but she is not able to get to the toilet in time because of difficulty with movement of her arms or legs. This person will need help from others in order to reach the toilet in time.

2.2.7 Extra Bone Formation

(also called Heterotopic Ossification)

In some persons after brain injury, the body begins to form bits of bone in places where normally there is no bone. Often this extra bone forms around the joints of the hips, knees, shoulders or elbows. As this new bone begins to form, swelling, redness and heat are noticed around the joint where the bone is forming. The person often feels pain when she

tries to move the affected joint. As the bone continues to form, the joint becomes less able to be moved. Another person who tries to help the person to move that joint will feel a hard stop to the movement.

This extra bone formation can cause a good deal of disability and pain. A person may not be able to walk or to move her arms to feed herself because the extra bone prevents her from moving her legs or arms.

Special medicines can sometimes be used to try to prevent this extra bone from forming. The person with brain injury should also be helped with exercises to move the affected joints as much as possible.

A person who has this problem will often need pain medicine, especially when the bone is beginning to form and there is swelling and heat at the joints. A doctor should be asked for advice about a pain medicine that is safe for a person with brain injury.

2.2.8 Problems With Stiff or Tight Muscles; Painful Limb Positions; and Shaking or Jerking Movements

Very often after a severe brain injury, a person may lose the ability to control the movements of the arms and legs. Some muscles may become stiff and tight, causing an imbalance of forces across the joints of the person's limbs. As a result, arms and legs may be pulled into uncomfortable and unnatural positions. In the leg, the foot may be pulled down at the ankle by tight muscles of the calf. Sometimes the knees and hips are pulled into a bent position because of tight muscles. Sometimes they are pulled out straight and the person is unable to bend the joint. The tightness or loss of control of leg muscles can make it very difficult for a person to walk or even to sit comfortably in a chair. A helping person may find it very difficult to assist the person with the injury to move from a bed to a chair because the person's feet cannot be placed flat on the floor.

For some persons, the fingers and wrist may be pulled into a bent position with the arm and hand held tight to the chest. These abnormal positions can make it difficult to clean the skin of the arm, chest and hand because different muscles are pushing so hard against each other that body parts cannot be easily separated. The following recommendations may reduce the problem:

- Move the person's arms and legs at least twice a day while trying to relax the muscles so joints can be moved.
- Use pillows and blankets to position the person in a way that reduces the amount of pressure on body parts. This will help reduce development of pressure sores.

- Use a splint to keep the limb in a better position. For additional instructions on making splints, see WHO Manual, *Training in the Community for People With Disabilities, "Training Package 13, for a family member of a person who has difficulty moving"*.

Sometimes a doctor will need to use drugs to relax the muscles. But drugs are not always able to relieve the problem and surgery may be necessary to lengthen or release (cut) the tight muscles.

A person with brain injury may have shaking or jerking movements in the arms and legs that she cannot control. (The person is fully conscious when these movements occur. ***She is not having a fit.***) The person usually does not have these movements when she is resting. The movements begin when she tries to make a purposeful action such as walking or using her hands to perform a task.

As yet, there is no medicine that can fix this problem when it is the result of brain injury. The person must be helped to learn ways to move and perform tasks that bring on as little of the jerking or shaking as possible. For example, sometimes a person can perform a task while seated and have less of the jerking or shaking than if she tries the task while standing. Other persons may need to use equipment such as a cane or a walking device or a brace to help keep balance in spite of the shaking and jerking movements.

2.2.9 Problems With Agitation and Destructive Behavior

After brain injury, some persons easily become angry, restless or excited, or behave in a manner that is not socially acceptable. A person may swear, yell or scream very vigorously and be unable to control this very unpleasant behavior. The person may hit or fight, pinch and bite, or break things for no clear reason.

This behavior can be very upsetting to others if it is not properly understood or managed. Often it may be possible to calm the person simply by talking quietly and in a comforting and reassuring manner. Sometimes soft music can help an agitated person to relax. Other persons respond best if taken to a quiet room and allowed to remain in that environment, away from other people, until they become calm. It may also be necessary for a doctor to prescribe medicine to help calm the person with brain injury who has the problem of agitation or destructive behavior.

2.2.10 Problems With Depression, Sadness and Feelings of Worthlessness

A person may become sad or depressed when he begins to understand what has happened to him and how he has been changed by the brain injury. Both men and women may spend a lot of time crying and may feel very despondent. Sometimes the person feels so unhappy that he wants to commit suicide. It is important to help the injured person to understand that he is still a good and worthwhile person who is valued by friends and family. It is important to help the person find enjoyable activities to do and tasks that he can successfully perform. This will help to distract him from negative thoughts. Sometimes it is necessary for a doctor to prescribe medicine to help brighten the mood of the person with brain injury.

2.2.11 Problems With Sleeping

The brain controls the cycle of sleep and awake time. After a brain injury, a person may stay awake at night and sleep during the day. He may have only short periods of sleep, or he may sleep a great amount of the time and have problems staying awake. It is very important to establish a normal pattern of sleep for the person who is recovering from brain injury. Lack of sleep will make it even more difficult for him to think clearly and perform tasks.

The person should be kept as physically and mentally active as possible during the day, so that when evening comes he is tired and ready to sleep properly. At night, his bed should be kept in a quiet place. Sometimes soft music or the sound of a familiar voice will help the person fall asleep. It may be necessary for a doctor to prescribe medicine for the person who has great difficulty falling asleep or sleeping through the night.

2.3 Changes in the Person that are Caused by Brain Injury

Brain injury sometimes changes the way a person is able to move and control her body. Brain injury almost always causes the person to have some mental changes. It is not possible to predict exactly what changes each person will have. This will depend on how severe the injury was and what parts of the brain were most injured.

Usually, the person shows the worst problems immediately after the injury. Most people recover at least some of their abilities over time.

Improvement is greatest in the first six months after the injury and then usually slows down. But a person with a very severe injury can sometimes continue to improve for many years.

Even though people with brain injury can improve their abilities, the injury should be thought of as a permanent injury. A brain injury causes cells to die. At this time, there are no medicines or treatments that can replace dead cells with new ones. Therefore, the injured person's brain cannot return exactly to the way that it was before the injury happened.

2.3.1 Physical Changes From Brain Injury Can Include:

Movement changes

- She has weakness on one or both sides of the body.
- She has stiff, slow or clumsy movements.
- Her movements are not coordinated.
- She has difficulty keeping balance.
- She has tightness, cramps or spasms of her muscles.
- She has weak or floppy muscles.
- She has difficulty making a movement, even though she tries very hard.

Changes in vision, touch, hearing, taste and smell

- He complains of seeing double or sees only on one side.
- He cannot tolerate bright light.
- He is not able to control eye movements.
- He cannot identify how close or how far away objects are located.
- He has loss of feeling in parts of his body.
- He feels pain when touched, bathed or when his hair is combed.
- He has difficulty tolerating loud noises.
- He has poor hearing.
- He has lost the ability to smell or taste food.

Changes in speech and language

- He has difficulty making sounds.
- He has difficulty saying words clearly, because his mouth muscles do not work correctly.

- He has difficulty understanding the words of others.
- He has difficulty finding the correct words to express thoughts – or says words that do not make sense.
- He has difficulty with reading or writing.

Other body changes include:

- She is always tired – even with only a little activity.
- She has changes in sleep habits – does not sleep well at night but falls asleep often during the day.
- She does not seem aware of hunger and thirst.
- She eats too much or too little.
- She has lost the control of her bowel or bladder, or does not sense the need to use the toilet.

2.3.2 *Mental (Cognitive) Changes From Brain Injury Can Include:*

Attention and concentration changes

- He has a short span of attention.
- He is easily distracted by activities happening around him, or by objects that he sees.
- He has difficulty following a conversation if more than one person is speaking.
- He has difficulty keeping his mind on what he is doing long enough to finish a task.
- He cannot pay attention to more than one task or idea at a time.

Changes in perception

- He ignores objects on one side of his body.
- He ignores one entire sided of his own body.

Changes in memory and learning

- She forgets recent events such as conversations, visitors or activities.
- She repeats herself when talking because she forgets that she has said it before.
- She does not remember the day, month or year.
- She is slow to learn a new task. She may need to practice many,

many times in order to learn it.

- She mixes past memories with what is happening now.

Changes in thinking and reasoning

- He thinks slowly or his thoughts change quickly from one topic to another.
- He has difficulty starting a task, or even thinking of a task to start.
- He has difficulty following directions for a task.
- He leaves tasks unfinished, or he repeats parts of the task over and over.
- He has difficulty deciding what to do in a new situation.
- He has difficulty making a decision.
- His thinking seems "childlike" or simpler than before the injury.

Changes in judgment

- She does not recognize that a situation or action is unsafe.
- She seems unaware of social rules for behavior. She talks too loudly or makes embarrassing statements.
- She is not able to determine if she has done a task correctly or incorrectly.
- She does not gather information that is important for doing a task correctly, or for making a correct decision.
- She becomes lost and wanders, even in her own community.

Changes in behavior

- He lacks interest in what is happening around him.
- He does not care that his body or clothes are dirty.
- He seems to care only for his own needs and has little thought for the feelings or needs of others.
- He acts in a restless or agitated manner.
- He easily becomes angry or hits or curses at people. He makes rude statements.
- He laughs when the situation is not funny, or cries without a reason.
- He often seems unusually irritable or demanding.
- He becomes confused, even in familiar situations.

- He often seems depressed, or he has quick changes of mood or emotions.
- He has trouble adjusting to any change in his routine.

Lack of awareness of the disability

- She has no sense that she has any problems with thinking or movement.
- She does not like to take help or direction from others, as she does not believe she has any need of help.
- She tries to do things that she is no longer able to do safely, and this may cause her to have another injury.

2.4 Helping the Person Learn and Perform Daily Activities

The following are general guidelines for helping a person with brain injury to relearn old skills and learn new ways of doing everyday activities. These guidelines can be kept in mind when reading Sections 3 and 4.

- Help her follow the same general routine every day. She will gradually learn it and start doing more on her own.
- Encourage her to take part in family activities. Allow her to help with familiar household chores.
- Do not try too many new tasks until she is able to do well on the more familiar tasks.
- Give her plenty of practice on difficult tasks. She should practice tasks in the same way each time. She should practice frequently for short periods of time, rather than spending long periods of time doing the same task over and over.
- Praise her for improvements. Remind her that she is getting better with practice.
- Watch her carefully for signs of tiredness. Allow her to take a rest break and then resume the task.
- Encourage her to do only one task or activity at a time and to finish the first task before starting another task.
- Do not rush the person with brain injury. Allow extra time to complete tasks.

- Make sure you have her attention before talking. Ask her to look at your face while you talk.
- Talk to her a bit more slowly than you did before the injury.
- Try to give just one direction or piece of information in each sentence.
- When more than one person is talking, each person should take a turn in speaking.
- Observe how the person reacts to noise and activity. Try to keep activities simple and quiet at home if she is upset by noise or by many activities occurring at the same time. Avoid loud music or loud radio or television.
- Help her decide how to spend her time. Avoid asking very general questions such as: What do you want to do? Instead, ask questions with two choices, such as: Do you want to help me at the market, or do you want to help your sister with the laundry?
- The person with brain injury may stop before completing a task or seem confused about what to do next. Or she may perform parts of the task out of order. If this happens, sit with her and give step-by-step instructions for the correct completion of the task.
- Wait until one step of the task is finished before giving instructions for the next step.
- If she does not seem to understand your instructions, show her what to do. If demonstration does not work, place your hand gently over her hand and move it in the manner needed to complete the task.

If the person forgets important information:

- Repeat the information as many times as necessary.
- Do not scold her for forgetting.
- If she can write, encourage her to write notes to help her memory. If the family uses calendars and clocks, point them out to her as you repeat information that includes dates and times.

2.5 Helping the Person Manage Anger and Frustration

Anger and frustration are common after brain injury. It is important to understand that brain injury may cause the person to have difficulty controlling his feelings and behavior.

If the person frequently becomes angry:

- Watch to see what situations seem to lead to anger. For example, he may become frustrated when he is unable to understand or to do something that was simple before the brain injury.
- When you have discovered what causes the anger, try to prevent it by giving the person extra help before he becomes frustrated. You may also choose to avoid an activity that often leads to anger or frustration.
- Do not punish or scold the person for getting angry. This will not help to prevent it from happening again.
- The angry person may not make sense about what is making him angry. Do not try to argue or reason with him. Instead, try to get the person interested in a different activity. Or try to talk about a different topic.
- Keeping calm is very important. You must be calm if you are to help the person with brain injury to calm down. Do not shout at, hit or threaten the person. Ask him to calm down so you can talk things over.
- Act calm so that the person will learn to be calm by watching you. Praise him when he stays calm in a situation that has caused anger in the past.

Do not touch the person until he has calmed, unless you must touch him to prevent him from doing something unsafe.

2.6 Sexuality and Relationships With a Partner After Brain Injury

Sexuality is more than the ability to experience sexual arousal, or perform sexual acts or reproduce. Sexuality includes the sense of being male or female and the expectations that come from social and cultural training. Sexuality includes the ability to feel love and to develop and maintain loving relationships. Brain injury can result in a wide variety of biological, physical and cognitive changes. These changes can have many consequences for the person's sexuality and personal relationships.

Brain injury may impair the function of brain structures that direct sexual urges. It may change the body's production of hormones and this can affect sexual desire. Lack of sexual interest is a common problem for a person who has had a brain injury. However, some persons with brain injury may also have decreased ability to control sexual urges, and this can result in problem behaviors.

Some men may have difficulty in achieving or maintaining an erection. A brain injury may also disrupt a woman's menstrual cycle, often for many months. (However, women with brain injury can become pregnant if they have unprotected sexual intercourse!)

A person, who is unable to move her arms or legs or has pain, may have difficulty finding a comfortable position for sexual intercourse. The person with deformed arms or legs may believe she is no longer attractive or desirable to her partner.

Brain injury may cause changes in sensation. A person may experience pain from touch, or parts of her body may not feel the touch of a partner. Such changes can reduce sexual arousal or make performance very difficult. Fear of causing pain may also reduce a partner's interest in sexual activity. Bowel or bladder control problems after a brain injury and can also affect intimacy and sexual opportunity.

Language and communications skills are an important part of sexuality and sexual relations. The person with brain injury and her partner may have to learn new ways to communicate intimate feelings, just as they must learn new ways of communicating about household tasks or self-care needs.

Cognitive and behavioral changes from brain injury have the most negative effects on sexuality and personal relationships. Cognitive changes are sometimes described as personality changes because the person seems so different from before the brain injury. She may not be able to express her emotions or control her emotions as well as before the injury. She may behave inappropriately in public in a way that is embarrassing to her partner. Irritability, memory loss or angry behavior may disrupt home life and weaken even a very strong, loving relationship.

For some couples, intimacy may be re-established as the person improves in cognitive and physical skills. Medication or other forms of medical treatment are helpful in some situations, especially to help reduce pain, improve movement, treat problems with erection and control hormone imbalance.

It is also important to remember that many loving partners do not have sexual intercourse but find much pleasure and value in simple physical closeness.

If counseling is available, a counselor may be able to assist the person and her partner to learn new ways to cope and adjust to the changes that are the result of her brain injury. A counselor may also be able to assist the person and her partner to find solutions to problems with sexual functioning or alternative ways of giving pleasure to each other.

A loving partner's support and understanding can assist a person to continue to have a positive sexual self-image and satisfactory sexual activity in spite of the many losses that result from brain injury.

Support and understanding from friends, family and the community is also essential to help the injured person and her partner find a way to continue the relationship, in a way that is as comfortable, personally acceptable and physically satisfactory as possible for both.

3

CARING FOR THE PERSON WITH BRAIN INJURY AT HOME AND IN THE COMMUNITY

3.1 Guides for Safe Medical Care and Prevention of Injury

3.1.1 Medical Safety

It is important to keep the injured person as healthy as possible. Family members must have accurate information about medical problems and medical needs.

In the picture below, the family keeps a book with written information about the person's medical needs, and a calendar for noting medical appointments. (fig. 5)

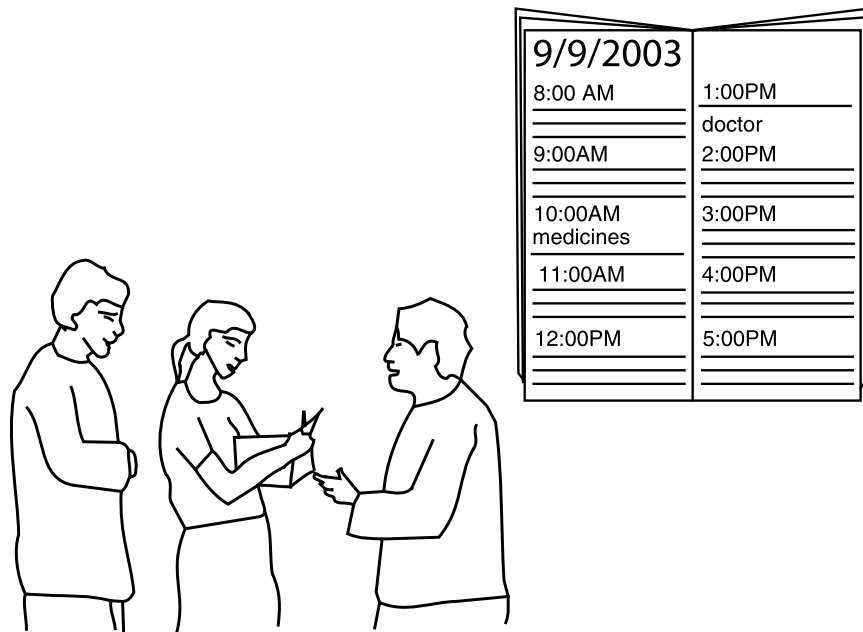

Fig. 5

Information About Medicines

Family members should know the purpose of medicines ordered by the doctors or hospital. This includes information about how and when to give medicine. The family must know if a medicine can sometimes cause a bad side-effect (an unintended problem). They must know how to recognize a bad side-effect and know what to do if a problem occurs.

The family must also know what they must do or where they must go in order to get the needed medicines or supplies.

Many medicines can be dangerous if used incorrectly. Medicines should be kept in a safe place, where they cannot be reached by children or otherwise misused. (fig. 6)



Fig. 6

Medical Treatments

A person may come home from the hospital with open wounds or broken bones that occurred at the time of the brain injury.

Remember that dressings or cloths used in wound care need to be very clean. Dressings or cloths that must be re-used should be washed in boiled water. All water used to clean open wounds or other open areas should first be boiled. (fig. 7)

Fig. 7

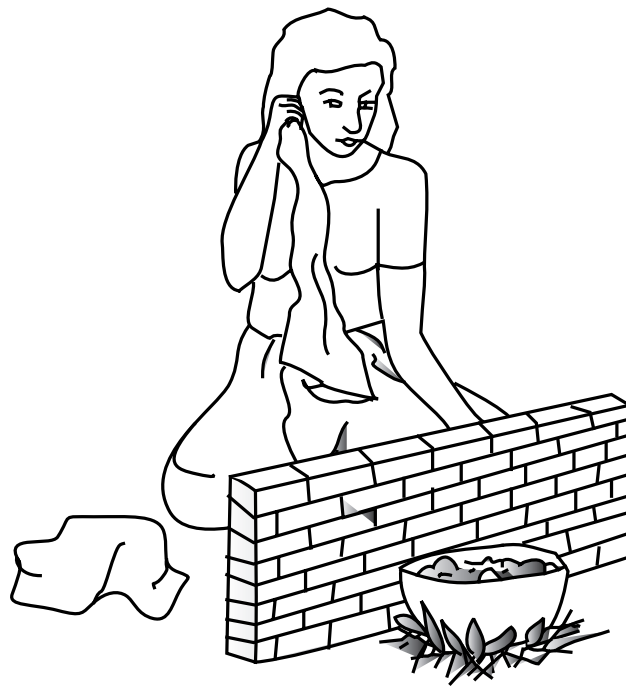

3.1.2 Making the Home a Safe Place

It is important to make the place where the injured person lives as safe as possible, to reduce her risk for more injury.

Falls

After a brain injury, the person may have difficulty seeing clearly, or hearing, or paying attention. She may have difficulty controlling the way her body moves or difficulty keeping balance. These difficulties will put the person at risk for falls.

Some areas of the home may be especially dangerous for the person who is at risk for falls. Family members should pay special attention to the following areas of the home:

Stairs

Keep stairs free of clutter. Railings should be securely attached to the wall. (fig. 8)

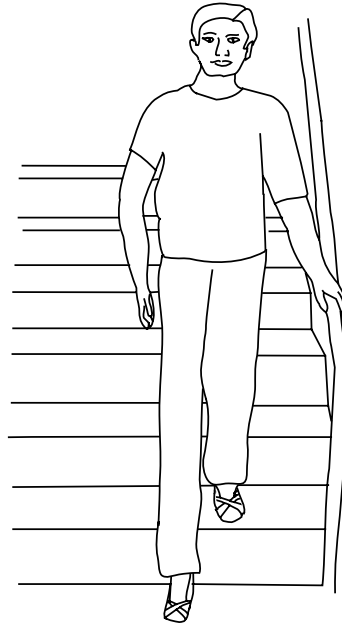

Fig. 8

Toilet and Bath Area

A frame around the toilet can help a person keep balance while urinating or defecating. (fig. 9) Washing from a seated position is safer than from a standing position. A restraint made from a belt or cloth should be used if the person has trouble maintaining sitting balance. (fig. 10) Always mop up spilled water from the toilet or bathing area. (fig. 11)

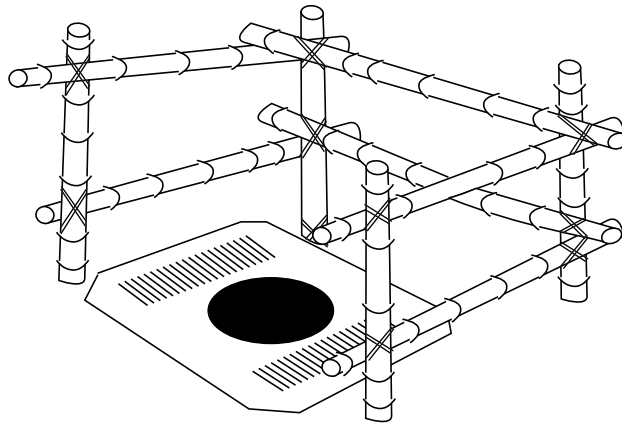

Fig. 9

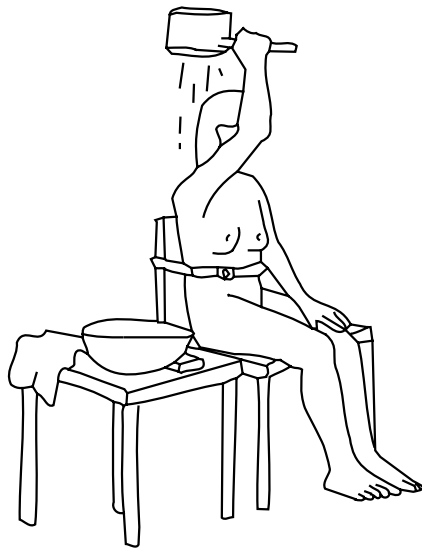

Fig. 10

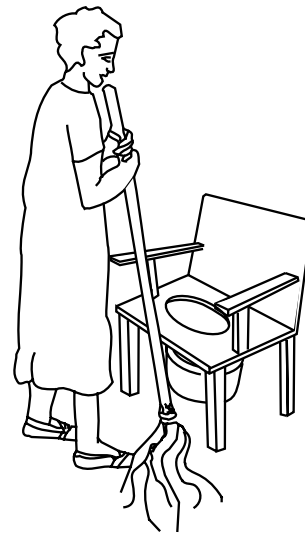

Fig. 11

**** See also: Section 4.6, Bowel and Urine Management**

Keep Rooms Free of Clutter

Place furniture or belongings so that the person can easily move around without tripping and falling. Shelves can be used to store household items. (figs. 12a, 12b)

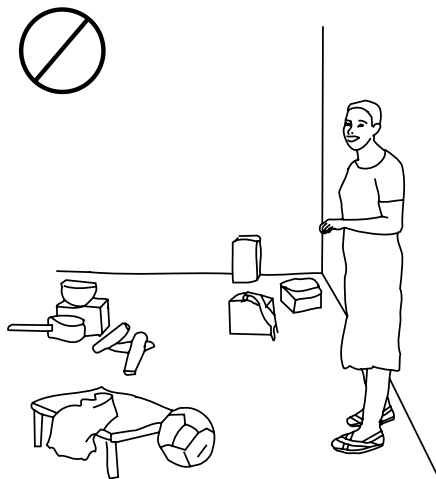

Fig. 12a

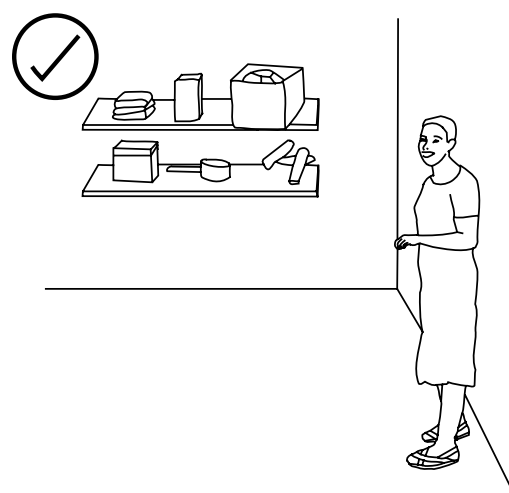

Fig. 12b

Cooking Areas

Cooking may be dangerous for a person who has movement difficulty or who has difficulty thinking or paying attention. Someone should stay with her when she cooks, until it is certain that she can cook safely without risk of being burned.

A person who has difficulty remembering or paying attention may accidentally start a fire if she forgets that something is cooking, or if she does not use the stove or other cooking equipment safely. Burns can also happen if a person loses balance and falls against a heater, stove or cooking fire.

Knives and other sharp cooking tools can be dangerous. The family should pay close attention until they are sure that the person can safely use knives and other cooking tools.

**** See also Section 4.11, Homemaking**

3.2 Information for Friends and Neighbors

Care for a person with brain injury requires a great amount of work from family members, especially in the first months that the person is home from the hospital. This is the time that the family must also learn how to cope emotionally with the injured person's mental or physical changes.

Family members may have feelings of fear or anger or even guilt about the injury. They may blame one another for not protecting the person from the injury. A family member may think: "I should not have allowed him to drive the car." Or "I should not have asked him to fix the roof." Or "His wife should have kept him from riding the bicycle after he drank beer."

These feelings are very painful and may cause serious family arguments. Often people do not have accurate information about how best to help a person after brain injury. Friends and family may think that he is sick and in need of long-term, constant care. They may feel responsible to provide for his every need. Such constant care may not allow the person the opportunity to re-learn skills or resume former responsibilities.

A person with brain injury may act confused, or agitated, or may behave in a strange or different way. Family members may worry that his behavior will be unacceptable to the community. They may then try to protect him from community disapproval by keeping him confined to the home.

Brain injury may also raise problems for family finances. Family members must often make the difficult choice between staying home to provide care or doing paid work. Often, when the injured person and his caregivers most need support and assistance from others in the community, they become isolated from those friends and neighbors. Isolation and lack of support will further add to the family's emotional and physical stress.

A main responsibility of the Mid-Level Rehabilitation Worker and other health care workers is to help people in the community to understand the special needs of a person with brain injury. When friends and community members understand why a person looks or acts differently after an injury, they can consider how best to help the person and his family. Likewise, when family members sense that friends and neighbors understand, they may feel more comfortable about asking for help with the person's care.

A Mid-Level Rehabilitation Worker may be able to assist members of the community to develop a schedule for sharing care duties so that family members have a chance to rest or attend to other responsibilities.

In some communities, the MLRW may find that there are several families who give care to persons with brain injury or other types of disability. The MLRW may assist these family members to meet one another, to share information about their experiences and draw on one another for emotional support or assistance in problem solving about care or management problems. The MLRW may also be able to explore ways to assist families to combine care resources, so that some caregivers are freed to resume paid work or other responsibilities.

Misunderstandings and Facts About Brain Injury

The following are some common misunderstandings and facts about brain injury that the MLRW can discuss with families and community members. The MLRW will need to refer to the information in **Sections 1,2,3 and 4** to prepare information and training for specific situations:

• People may believe that a person with brain injury is sick and needs constant care because he can do nothing for himself.

This is wrong! A person with brain injury may be able to relearn many skills and resume many former responsibilities. However, he will not relearn skills if he is not given the opportunity to try.

• Some people believe brain injury is a punishment for sins or bad behavior, or that the changed behavior is because of witchcraft or an evil spell.

He has impairments because his brain was injured, not because he did something wrong or because someone wished evil on him.

• *People may be fearful that the person with brain injury is sick and that his sickness can be passed to others.*

Brain injury is not an illness and other people can not catch it.

• *People may feel ashamed if a family member is physically or mentally changed. They may believe others will think they are not taking good care of the person if he does not look the same as before, or does not recover all of his former abilities.*

Many of the effects of brain injury will be permanent. Even excellent care will not be able to fix all of the results of a brain injury. However, it is possible for a person to have a good life again, even if that life is changed.

• *Some people believe that brain injury causes a person to become mad (crazy). They believe the person with brain injury should live apart from the community because they fear that the person will be violent or dangerous.*

Brain injury does not make people mad or crazy. However, some persons do show strange or angry behavior after a brain injury. Often the person shows angry behavior because he cannot think or move as before, or because he cannot control his emotions. Angry behavior can be a very difficult problem for the person and for his family. Medicines may sometimes help control the problem behavior. Friends and community members may also need to help a person relearn more acceptable behavior.

Providing accurate information is the MLRW's first step in development of family and community understanding of brain injury and brain injury rehabilitation.

The next step is to assist the family and community to learn how best to interact and communicate with the injured person, so that he can return to an active and useful role in his home and community.

Section 4 of this manual presents specific recommendations and instructions for retraining people with brain injury to do their personal care and functional skills.

4

INSTRUCTIONS FOR HELPING PEOPLE WITH SPECIFIC PROBLEMS CAUSED BY BRAIN INJURY

4.1 Unresponsiveness

How to Help the Person who is Minimally Responsive to People and Situations

The person with extremely severe brain injury may remain only minimally aware of his surroundings for a very long time. Sometimes he will remain in this state until he dies. However, some of these people eventually regain some of their abilities. For this reason, it is important to provide very good and protective care, to give the best opportunity for improvement. The following recommendations are important for care of the person who is only minimally responsive:

4.1.1 Interaction and Communication With the Person Who is Minimally Responsive to Persons and Situations

It is important to talk to the person who has had a brain injury, even if it is not certain that he can understand. Speak clearly, in the way that you would ordinarily speak to an adult. (Do not use child-like words. The person may appear helpless, but he has not become a child.)

Tell him about his injury. Tell him what happened and where he is now. Tell him when you must do something for him, such as bathe him or change his clothes. Tell him about family news and about events in the community. Speak slowly and give him adequate time to make a response. Even though he is not able to show a response to your words, he may be able to take comfort from your voice.

4.1.2 How to Determine if the Person is Aware and Has Ability to Understand

A person with a very severe brain injury who lies in bed and does not

she may not be aware of her surroundings. Or she may be somewhat aware, but not able to speak. Family members can learn about the person's ability to understand by observing eye opening, response to sounds and movements. These observations can be used to answer the questions: Can she see? Can she hear? Can she make a movement to respond to a command? Can she use movements to communicate?

Eye opening:

Immediately after a severe brain injury, the person's eyes will usually be closed. Often the eyes will open after several days or several weeks. The person is considered to be awake when her eyes are opened for longer periods of time and then are closed as if she is sleeping. However, a person whose eyes are open may not see or be able to understand everything that is going on around her.

Can the person see?

If her eyes are open, watch to see if she follows you with her eyes and head when you move around the room.

Hold an object in front of her eyes. Slowly move it up and down and left and right. If she follows the object with her eyes, she may be able to see. If you find evidence that she can see, try to determine if she can use her vision to follow a command. Gesture with your hand in the direction you want her to look. For example, point to the window or to an object in the room.

It is best to combine verbal information with your hand gestures. Your words may help her to understand what she sees and what she needs to do.

Response to sounds:

Brain injury can change the person's ability to hear sounds or to understand language.

Can she hear?

Watch to see if she opens her eyes or moves when there is a sudden loud noise. For example, try clapping your hands quickly and loudly, or try banging on a pot.

Stand to her side and ask her to move her head towards you. (Do not give a hand gesture as you are trying to learn about her ability to hear)

Move to her other side and repeat the directions. Watch to see if she can follow a direction better from one side or the other.

Movements:

A very severely injured person may have minimal or no movements of the limbs. Other severely injured persons may make many movements with the arms, legs, fingers, head and mouth. Some kinds of movement indicate that a person may understand something about what is happening around her. For example:

- She may reach for your hand.
- She may grab at her clothing or blankets.
- She may push you away or pull you towards her.

Can the person move in response to a command?

Sometimes a person who is minimally responsive may be able to make a movement that you ask her to make.

Put your hand in her hand and ask her to squeeze. If you find that she is able to squeeze your hand, ask her to stop squeezing and hold still. Her response to these commands will help you learn how much control she has over her movements.

Using movements to help the person to communicate:

If she can move, she may be able to use her movements to communicate YES and NO. Any movement that the person can control can be tried for communication. For example: she may move her eyes up and down or left and right. She may use head nods, head turns, hand movements or leg movements.

If the person can make a movement to squeeze your hand, ask her to squeeze one time for YES and two times for NO. (fig. 13)

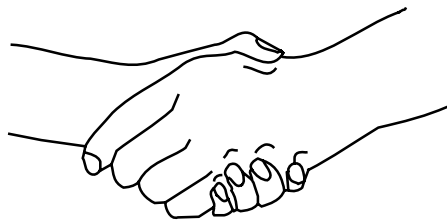

1 squeeze YES 2 squeezes NO

Fig. 13

- She may be able to use a foot to kick one time for YES and two times for NO.
- She may also be able to do a thumbs up for YES and thumbs down for NO. (fig. 14)

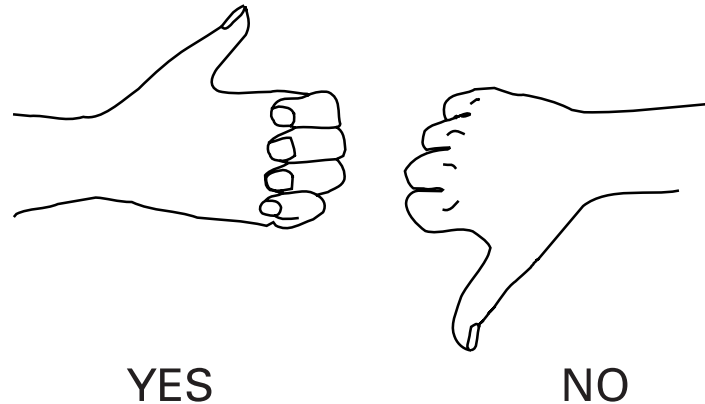

Fig. 14

Choose the movements that are easiest for the person to make. Once you choose the movement sign for YES and NO, use only that sign. Do not confuse the person by asking her to use different movement signs at different times.

To test the YES and NO signs, ask her questions that are easy and have answers that she has known for a long time. Ask her if she is a woman. Then ask if she is a man. Ask her if she is married. Then ask her if she is not married. Ask her if her name is (correct name). Then ask her if her name is (incorrect name).

Remind her of the YES and NO signs every time you ask a question. For example, remind her that thumbs up means YES and thumbs down means NO. Then ask the question.

Asking simple questions with known answers is the best way to learn if a person understands what she is asked and if she can use the identified YES and NO signs to communicate.

Teaching the person to communicate basic needs:

Once you feel certain that she can use her YES and NO signs accurately, you can begin to ask questions about her basic needs. For example: you can ask her if she is in pain (YES or NO) or if she is comfortable (YES or NO).

You may need to repeat questions. Speak slowly and use a normal tone of voice.

4.2 Basic Care for the Person With Severe Brain Injury

How to Help People Who Have Minimal Ability to Move or Perform Personal Care (This Person May or May Not Have Ability to Understand)

A person with a severe brain injury almost always needs hospital care at first. Often, the person will need a tube to help with breathing. He may need to take food and liquid by stomach tube. He may have fractures or open wounds that require daily care from doctors and nurses. However, after a period of time, he may recover the ability to breathe, eat and take fluids without tubes, even though he still can not move or do much for himself.

That person will still require a great amount of care, even though he does not require the daily attention of doctors and nurses. Family members, friends and neighbors may be able to learn how to provide for his continuing care needs in the family home.

The following are some of the most important instructions that a family will need to learn in order to provide care at home for a person who has minimal ability to move because of brain injury:

4.2.1 Good Skin Care (To Treat Or Help Prevent Sores)

Look at the person's skin closely. If the skin has an open sore or wound it must be washed daily with boiled water and covered with clean cloths. Medicine may be needed if the person has sores that look infected. (The sores are infected if they have green or yellow pus, or are warm to the touch.)

When the person urinates or moves his bowels, it is important to clean his wet or soiled skin as soon as possible. Urine and feces that continue to lie on the skin can cause the skin to develop open sores.

It may help to have the person lie on a pad or pillow that is stuffed with absorbent material such as kapok, cotton, leaves or straw. The stuffing can be thrown away when it becomes soiled and the pad or pillow cover can be washed and stuffed again with clean material.

The skin can also become red where it is pressed against the bed, pillows, covers or other objects. It is important to turn the person in bed every 2 to 3 hours during the day and night. Each time he is turned, check the skin for red marks.

Pay close attention to any red marks that do not go away after the person's position changes. Try to keep the red areas from touching anything else until they do disappear. (figs. 15a, b, c)

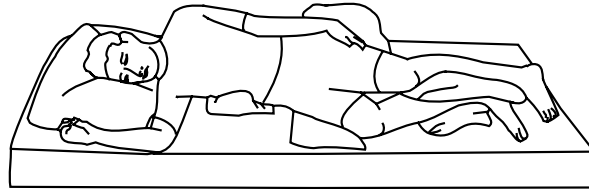

Fig. 15a

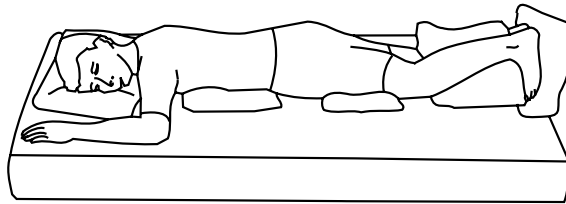

Fig. 15b

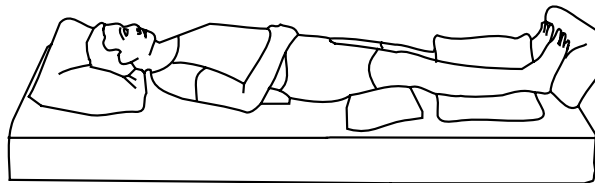

Fig. 15c

4.2.2 Reducing the Risk of Limb Deformity

A person with severe brain injury who is unable to move his own limbs may gradually develop deformities in the limbs that do not move. This is because a severely injured brain cannot give coordinated instructions to the nerves that carry messages to the muscles. As a result, some muscles remain strong while others become weaker. The stronger muscles may pull or twist the person's limbs into abnormal positions. At the same time, lack of movement can cause the joints of his limbs to become stiff.

If stiffness and deformity develop, it will become even more difficult to turn him, to change his position in bed, or to clean his body. It is not always possible to prevent stiffness and deformity in a severely injured person who does not move. The following are some ways to limit development of deformities:

Change the way the person lies in bed several times each day and during the night. Do not allow his upper body or limbs to remain in the same position for long periods of time.

Bend and straighten the joints of each limb several times each day.

Use splints to keep the limbs as straight as possible. Make sure there is a thick layer of soft cloth between the limb and the hard material of the splint.

Sometimes the person's limbs may rub or press together. Fingers may curl in toward the palm or form into fists. If this happens, sores can develop at the places where the limbs or fingers rub together.

Separate legs that are rubbing or pressing together by placing a pillow or a large roll of soft cloth between the legs. (fig. 16)

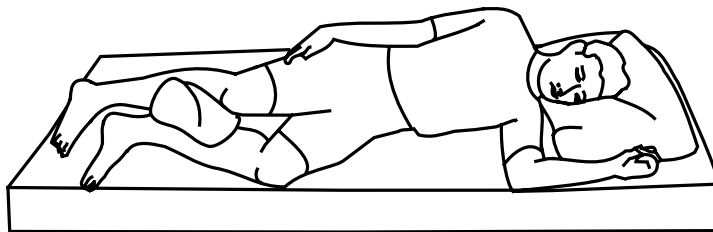

Fig. 16

If a person's arm is tightly pressed to the chest, place a thickness of soft material between the arm and chest at the place where they press together. Separate fingers that are pressed tightly together by placing small rolls of soft cloth between the fingers. (fig. 17)

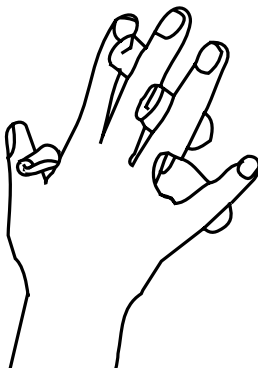

Fig. 17

A small roll can also be placed between fingers and palm (fig. 18)

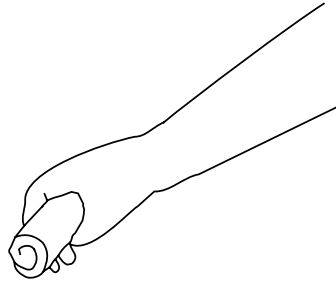

Fig. 18

A footboard can be used to hold the feet in a flat position in the bed, so that toes and feet do not begin to point down. (fig. 19) Put soft padding under the ankles to protect the heels. Use foam rubber or soft cloth.

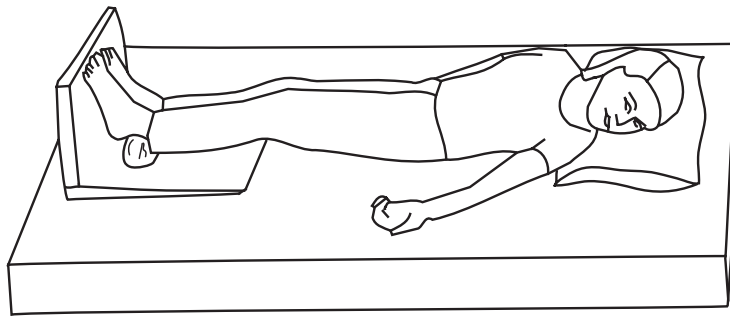

Fig. 19

4.2.3 Sleep and Rest

The person may need more sleep at night than she did before the injury. She may also need to take several naps during the day. The person's sleeping place should be a quiet place, away from other family activity, but close enough so that the family can easily check for her needs.

Remember to change her position every few hours, even during the night.

4.2.4 Breathing and Protection From Choking

The person who cannot move on her own should lie in a position that helps her to breathe easily. Move pillows and blankets away from her face.

If the person has difficulty breathing while lying flat on her back, use pillows or rolled blankets to raise her head and chest. (fig. 20)



Fig. 20

The person should be helped into a sitting position while she is being fed or while drinking. She should remain in this raised position for an hour after feeding. This position will help prevent her food from coming back up from the stomach and possibly causing her to choke. (fig. 21)

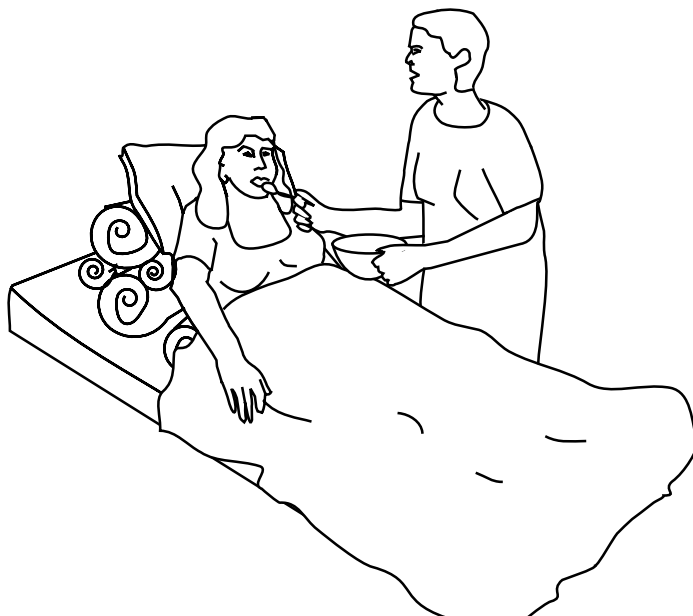

Fig. 21

If she vomits, quickly turn her on her side so that the vomited food does not get stuck in her throat. (fig. 22)



Fig. 22

4.2.5 Management of Urine and Feces

Every person needs to have regular bowel movements and urination. This is the way our bodies remove waste materials. Make sure the person is having regular bowel movements. If not, feed her foods that will help to move the bowels. Fruits and grains are most helpful for stimulating bowel movements. Water is also necessary to keep the bowels moving regularly. The person should drink water several times each day. (fig. 23)



Fig. 23

If the person is not having regular bowel movements, she may have an impaction. This means that the feces are trapped in the bowel. A doctor may recommend the use of a vegetable oil or liquid Vaseline that is inserted into the rectum to help remove the feces.

A helping person may also provide assistance to loosen the impaction by gently inserting a finger into the opening of her rectum (anus) and making a circular motion with the finger. If disposable rubber gloves are available, the helper should wear a glove on the hand that is being used. A small amount of vegetable oil should also be used to lubricate the finger (whether or not gloves are used). Pressure from the finger can start movement of the muscles of the bowel to push out feces. The helper must be sure to wash hands thoroughly with soap after helping to remove the feces, even if disposable gloves are used.

A person with severe brain injury may become at risk for infection in the bladder or kidneys. A helping person should regularly check the urine color and odor. Urine that is cloudy or red in color or urine that has a strong odor is often a sign of infection and the person may require medicine. Dark brown urine is a sign that the person needs more water. Yellow urine is healthy.

Some persons with brain injury have difficulty releasing all of their urine because the muscles of the bladder do not function correctly. Sometimes an infection can prevent release of urine.

A person with this difficulty may need to have a catheter tube inserted into the bladder to allow the release of urine. A doctor or nurse will need to insert the catheter tube, but family members can be trained to manage the catheter and keep the catheter site clean and free from infection.

If the person cannot get up out of bed to go to a toilet to urinate, a helper should offer a urinal or a pan to catch the urine. Set up a schedule to help the person urinate every 2 to 3 hours. This helps the person to establish a urination routine. (fig. 24)

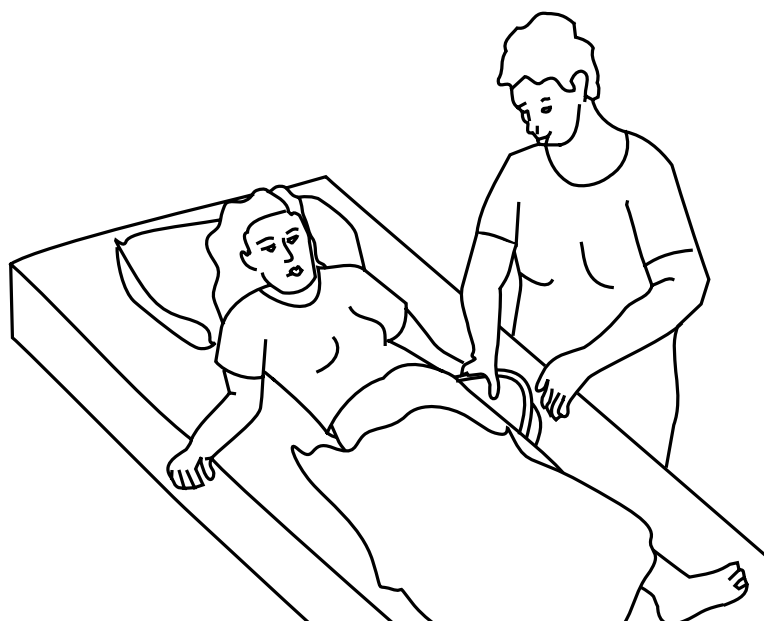

Fig. 24

If the person cannot urinate into a urinal or pan, place pads of absorbent material under her body to catch urine and feces. *As previously discussed under 4.2.1 GOOD SKIN CARE, the soiled materials should be removed as frequently as possible to prevent injury to the skin.*

4.3 Movement

How to Help People Who Cannot Move Parts of Their Bodies

After brain injury, movement is important to prevent stiffness and deformity. Deformity means that a body part has stiffened into an unnatural position and now cannot easily perform normal movements.

When a person cannot move his arms or legs, the joints sometimes become stiff. When joints are stiff, the arms and legs can become deformed. Arm and leg deformities make bathing, dressing, using the toilet and sitting up very difficult. Deformities can also prevent a person from standing and walking.

4.3.1 How Joints Become Stiff

If a person cannot move on his own and no one moves his limbs, his arms and legs will stay in the same position and this can lead to joint stiffness.

If movement causes pain, a person may try to prevent pain by lying still in the most comfortable position. A body part that stays in one position for a long time can become stiff and deformed. This can happen in the arms, legs, hands feet, neck and back.

4.3.2 How to Help a Person Prevent Stiffness and Deformity in the Joints

Change the position of the body and limbs several times during the day and night. Help the person lie on his back or stomach, then on his right side or left side.

Move the joints several times a day, slowly and gently. Do not force a joint to move. The person may have some pain, but should not have a great deal of pain.

Keep the joints in straight positions during the day and night when the person is asleep. The person may need splints to keep the joints in a straight position. (fig. 25)

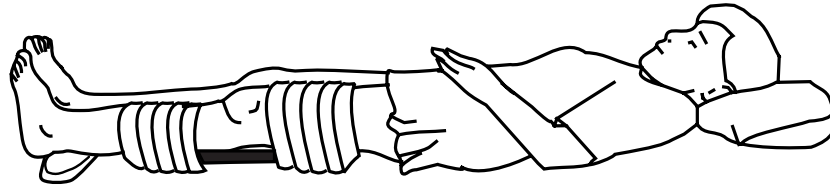

Fig. 25

4.4 Eating and Drinking

How to Help People Who Have Difficulty Eating or Drinking

4.4.1 Helping the Person Who Has Difficulty Swallowing

A brain injury can cause both physical and thinking difficulties that interfere with the ability to swallow. Problems may include weakness or difficulty with coordination of the muscles in the mouth or throat. The person's lips, tongue and jaw may not move easily and this can cause difficulty with chewing and swallowing.

Swallowing problems can cause many serious conditions including pneumonia, choking, loss of body fluids (dehydration) and weight loss (malnutrition). Choking can lead to death if the person cannot clear her airway to breathe.

If swallowing muscles do not work correctly, food or liquid may drop into the person's lungs and cause pneumonia. Pneumonia can lead to death. A high fever can be a sign of pneumonia.

Weight loss (malnutrition) can lead to many kinds of health problems. Poor nutrition can affect the person's ability to heal fractures, wounds or bedsores.

Loss of body fluids (dehydration) can cause serious infections and can cause the person to show decreased mental ability.

Look for these signs of difficulty when the person is drinking:

- The person coughs.
- She makes frequent attempts to clear her throat.
- Her voice sounds wet or gurgling after she swallows.
- Her swallow is delayed (compared to your own).

If the person has difficulty swallowing liquids:

- Make sure the person is sitting upright. Support her head if necessary.
- Encourage her to take one sip at a time.
- Help lower her chin down toward her chest as she swallows. (Her chin should remain down toward the chest until she completes the swallow)
- Try giving liquids by spoon or straw.
- Ask her to swallow two times for each sip. (The extra swallow will help clear remaining liquid from the throat)
- Ask the person to take a breath and hold it, then swallow and breathe.
- Thicken liquids. Add cornstarch, potato starch or flour to the liquid. (Start by making the liquid about the same thickness as honey. If the swallowing improves, decrease the thickness and watch to see if she continues to swallow without signs of problems.)

Look for these signs of difficulty when the person is swallowing solid food:

- The person chokes or gags.
- Food spills out of the mouth or nose.
- The person refuses to eat.
- Food sticks at the top or side of the mouth or on the tongue.
- The person shows shortness of breath while eating.
- Food comes up from the stomach into the nose or throat.
- She clears her throat frequently while eating.
- Her swallow is delayed (compared to your own).

If the person has difficulty swallowing solid foods:

- Make sure the person is sitting upright. Support her head if necessary.

- Cut up the food into small pieces (including bread).
- Avoid hard to chew foods like hard bread or meat, or raw vegetables.
- Puree food (like baby food).
- Give her sips of liquid in between bites of food.
- Tell her to take small bites – no more than one spoonful at a time.
- Tell her to place food and chew on the stronger side of her mouth.
- Show her how to use her tongue or finger to move food from the weak side of the mouth to the strong side.
- Assist her to sit upright for 30 to 60 minutes after eating.
- Check between swallows and after the meal to make sure there is no food left in the mouth.

Cognitive (thinking) difficulties to look for when the person is eating or drinking:

- She has difficulty paying attention to the task of eating. (For example, noises or people coming into the room take her attention away from her food)
- She shows restless behavior.
- She talks constantly. (She does not eat because she does not stop talking)
- She has difficulty remembering instructions for safe swallowing.
- She stuffs food into her mouth or eats too quickly to be safe from choking.

If the person shows thinking problems that affect swallowing:

- A helping person should remain with her to assure that she eats and drinks safely.
- Serve smaller, more frequent meals.
- Place her in a quiet area for eating and drinking.
- Offer one item of food at a time.
- Remind her to take small bites and to eat slowly.
- Do not talk to her while she is eating or drinking.
- Do not feed her if she is restless or tired.

First Aid for Choking (The Heimlich Maneuver)

The Heimlich Maneuver is the best known method of removing food or another object from the airway of a person who is choking. A person who is truly choking cannot speak and cannot cough. A person who shows distress and cannot speak or cough must have immediate help to remove the obstruction.

1. Stand behind the choking person. Bend the person slightly forward and wrap your arms around his waist.
2. Make a fist with one hand and place it slightly above the person's navel.
3. Grasp your fist with your other hand and press hard into the person's abdomen with a quick, upward thrust. Repeat this procedure until the object or food is expelled.

The illustrations below show how the Heimlich Maneuver can be performed on the choking person who is standing, sitting or lying down. (fig. 26 a, b, c)

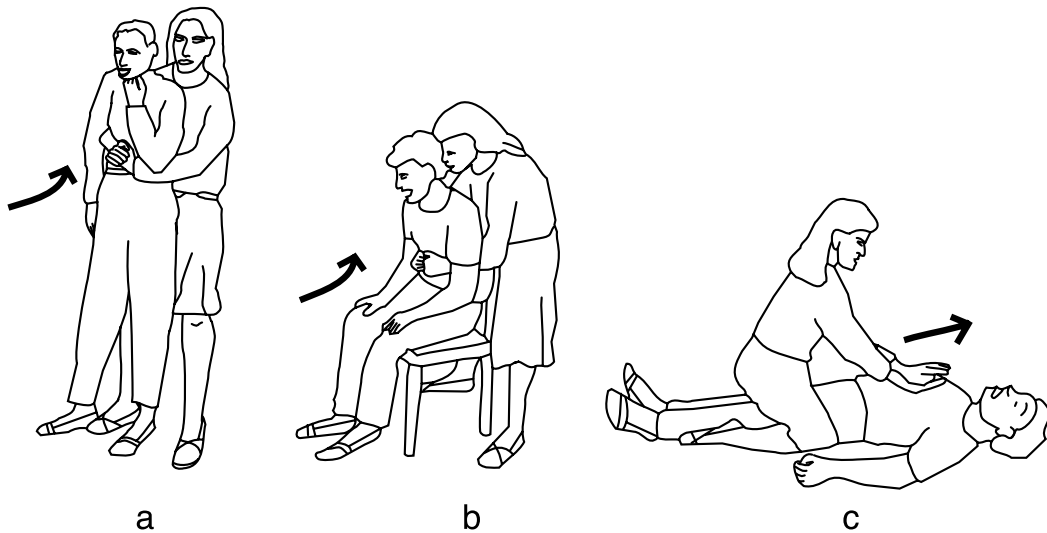

Fig. 26

4.4.2 SELF-FEEDING

Brain Injury can cause cognitive, vision, and movement difficulties that affect the person's ability to feed herself. The person may need training to re-learn the steps involved in this skill. She may need to learn ways to compensate for a vision impairment that affects her ability to see what she is eating. A person who has difficulty with movement may need special devices or other physical assistance to help her to feed herself.

The following are suggestions for helping the person with brain injury to re-gain the ability to feed herself.

Cognitive difficulties that affect self-feeding:

The person may have difficulty paying attention to the task of self-feeding.

- She should eat in a quiet place.
- Limit the number of people in the room to only the person eating and a helper.
- Limit the items on the table to only those that she will use for self-feeding.

The person may have difficulty getting started or continuing with feeding herself. She may not seem to know what to do. Try to help her by following these instructions, in the order given.

1. Tell the person what needs to be done.
2. Point to the item that should be used.
3. Demonstrate what should be done.
4. Take her hand and move it in the desired direction.
5. Place your hand over her hand and move it through the action a few times.
6. Remove your hand and see if she can continue without assistance.

Vision difficulties that affect self-feeding:

A person with brain injury may have difficulty seeing things on one side. The following are suggestions that may help her learn to compensate for the impairment.

- Remind her to look to the side that she has difficulty seeing.
- Help her to locate items on the problem side by providing a target object to look at, such as a brightly colored object. When she turns her head to look at that object, she will see other things that she has missed on that side.
- Put food or other objects in the same place each time so that she will learn where they are located (even if she does not see them).

If she continues to have difficulty learning to look for items that she cannot easily see, simply place the objects on the side that her vision is stronger. (fig. 27)

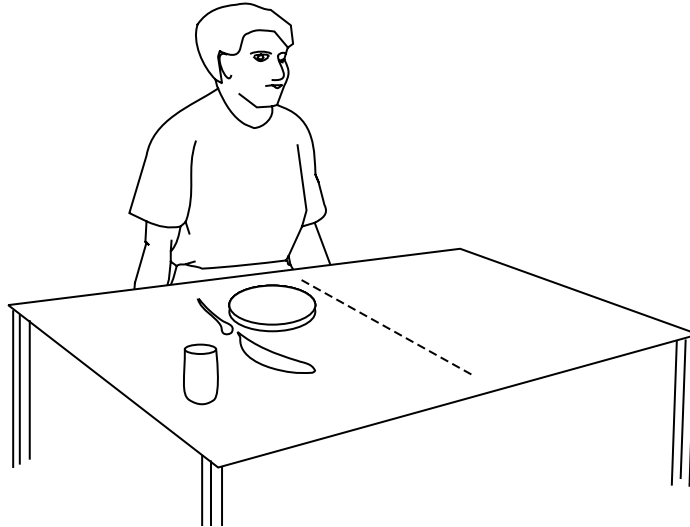

Fig. 27

The person who is blind will need special help to learn where food is located.

- Set the plate, cup and utensils in the same place on the table for each meal. Place the food in the same place on the plate.
- Use the Clock Method to describe the location of the food. For example, "The rice is at two o'clock. The vegetables are at ten o'clock. The meat is at six o'clock." This method can be used to describe the location of the plate, bowls, cup and spoon or fork. (fig. 28)

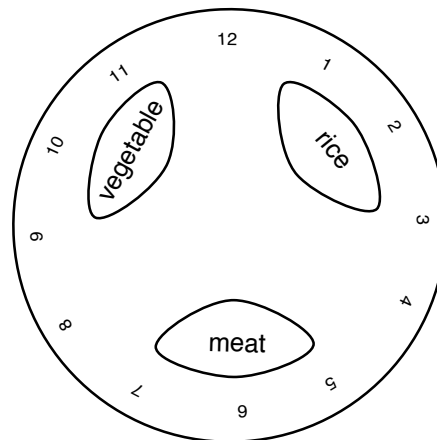

Fig. 28

- Use a plate that has dividers or separate bowls for each item if the person is to eat more than one type of food during the meal. (fig. 29)

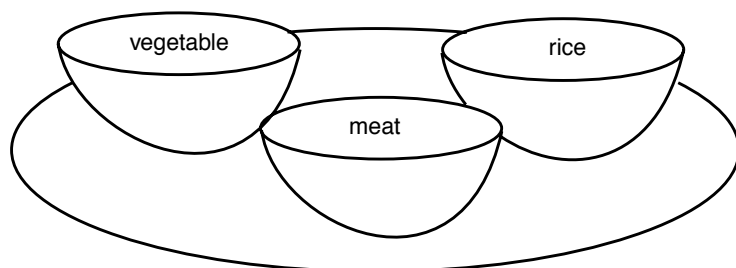

Fig. 29

Movement difficulties that affect self-feeding:

A person may have difficulty maintaining balance while eating.

- Help the person to sit in an upright position with back, feet and arms supported. (fig. 30)

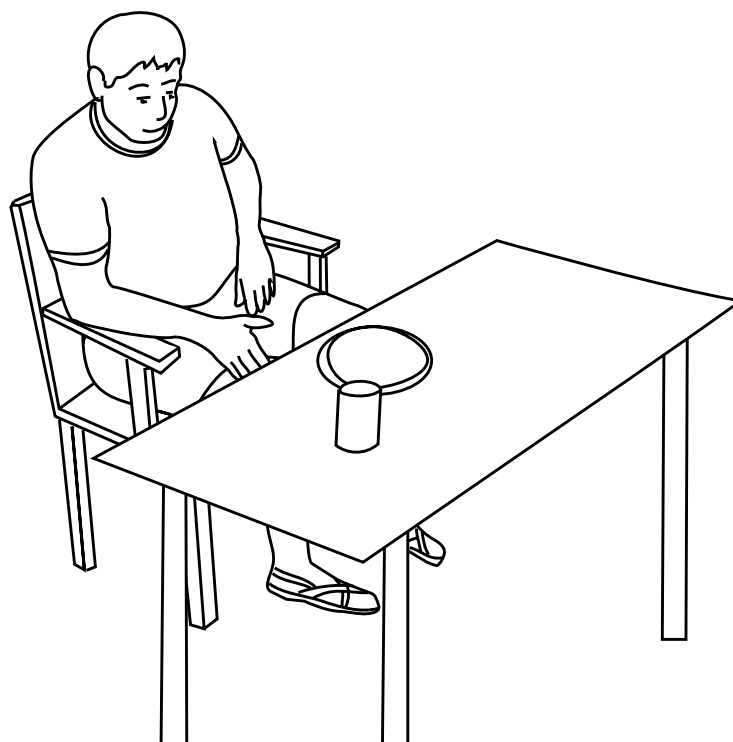

Fig. 30

- If the person is unable to sit in a chair, prop her in bed with boxes or blankets.
- If she usually sits on the floor, someone can sit behind her to provide back support. Or she can be positioned with her back against a wall.

A person may have difficulty holding utensils.

- She may need to eat with utensils other than the ones she used before the injury. For example, a person who used chopsticks may now need to use a spoon. Or her utensils may need special adjustments so that she can use them with her limited movement. The following are suggested ways of modifying utensils or otherwise assisting the person with movement difficulty to self-feed.
- Increase the size of the utensil. Wrap a small piece of foam rubber or wood around the handle.
- For a person whose fingers are bent but have some strength, change the shape of the handle to a T-shape. For example, you may attach a piece of wood to the handle. (figs. 31a, 31b)

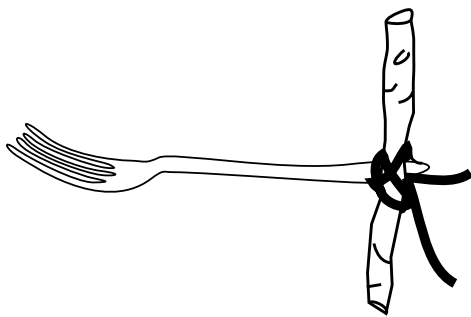

Fig. 31a

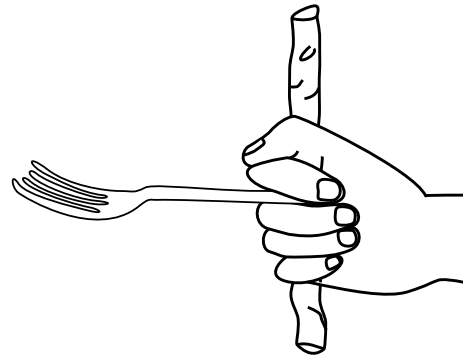

Fig. 31b

- Someone who does not have hand or finger strength may attach the utensil to her hand, using tape, ribbon or string. (fig. 32)

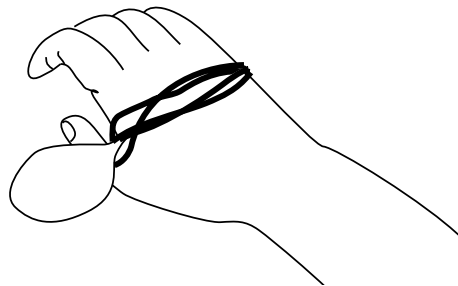

Fig. 32

- A person with arm weakness may need to use books or boxes to support the elbow of the arm that holds the eating utensil. (fig. 33)

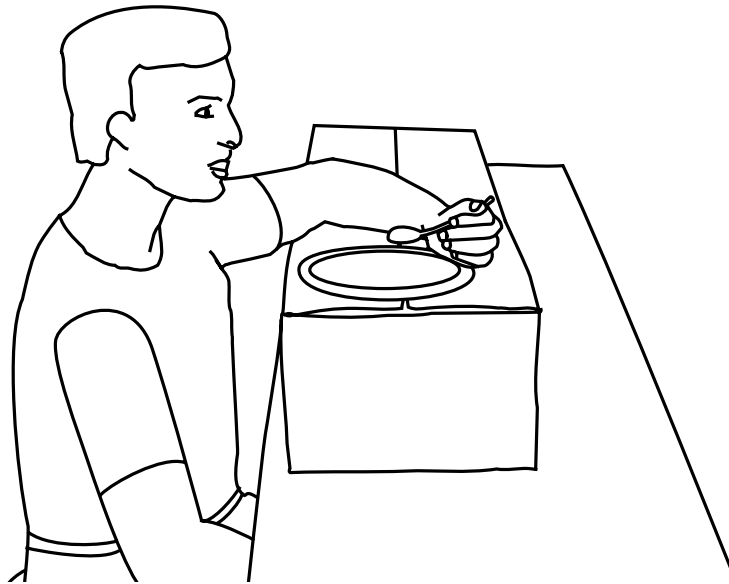

Fig. 33

- Attaching a long handle to the utensil can also help. (fig. 34)

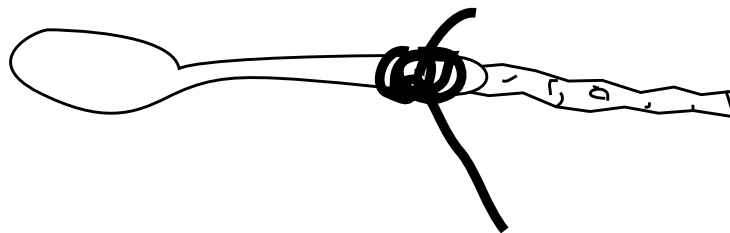

Fig. 34

- If the person has uncontrollable shaking, you may support her elbow on a table or against her body. Or you may add weight to her wrist. For example, a small bag of sand may be used to make a weight. (fig. 35)

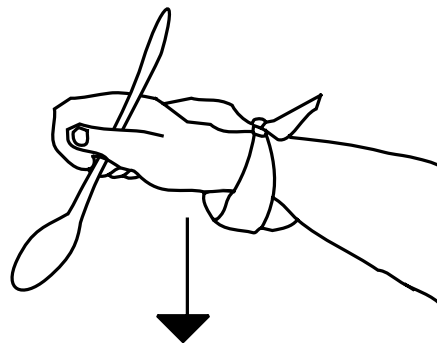

Fig. 35

- A heavier spoon or fork may help the shaking person. For example, use bamboo to make a wooden tube. Close one end with a cork. Fill the tube with sand, clay or cement. Then put the handle inside. (fig. 36)

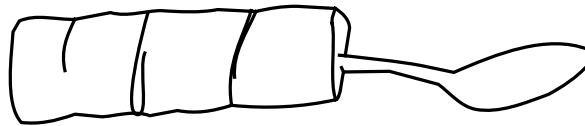

Fig. 36

A person who shakes may also use a weighted cup. To make a weighted cup:

- Take two cups. One cup should be taller and thinner than the other.
- Place the tall thin cup inside the shorter cup. Fill the space between the two cups with clay or cement. (fig. 37)

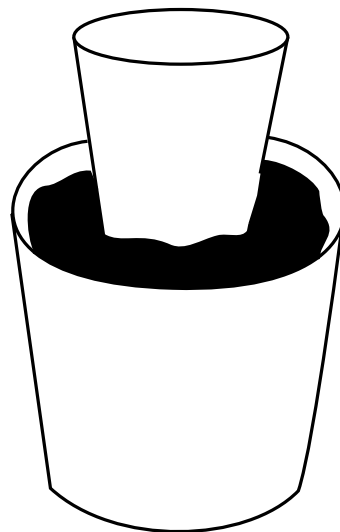

Fig. 37

- A person who is unable to hold a cup may be able to slide a hand in through the opening of the cup handle. (fig. 38)

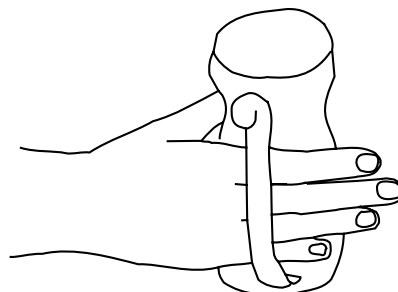

Fig. 38

- A straw may be helpful if she cannot hold a cup or cannot bring the cup to her mouth. (fig. 39)

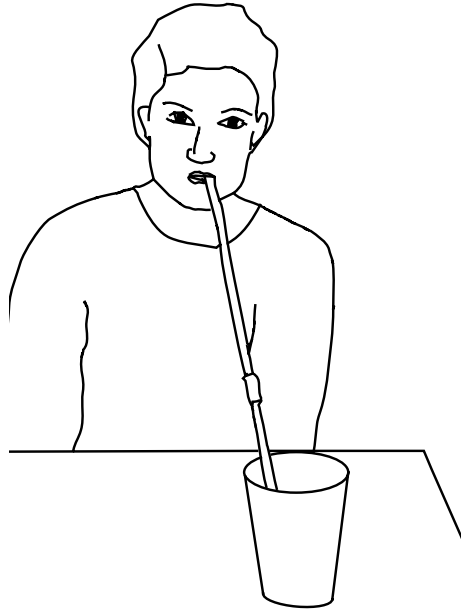

Fig. 39

To hold a bowl or plate in place and prevent it from moving while the person is scooping food:

- Place a piece of rubber under the plate.
- Use a heavy bowl.
- Place stones or other heavy items around the plate.

The person may also use a bowl instead of a flat plate. It is easier to scoop food from a bowl or plate with a raised lip at the edge.

A person with a deformed hand may have difficulty grasping a handle. Bend or change the angle of the fork or spoon handle. (fig. 40)

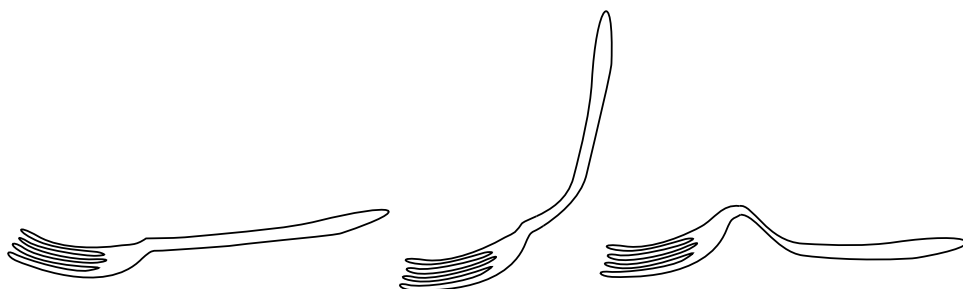

Fig. 40

4.5 Washing and Bathing

How to Help People Who Have Difficulty Washing and Bathing

A person with brain injury may have difficulty sensing the temperature of bath water. The sensation may be so poor that he can burn his skin but not feel it. Check the water temperature before the person bathes.

If he has open sores, it is very important to boil the water that is used for bathing. Then cool the water to a safe temperature. Even water that appears to be clean may contain germs. Bathing a sore with water that was not boiled can cause an infection in an open sore.

If the person has poor balance, provide him with a railing or pole to hold while standing in a shower to bathe. The railing can be secured next to the shower or water spigot so the person can hold it easily. (fig.41)

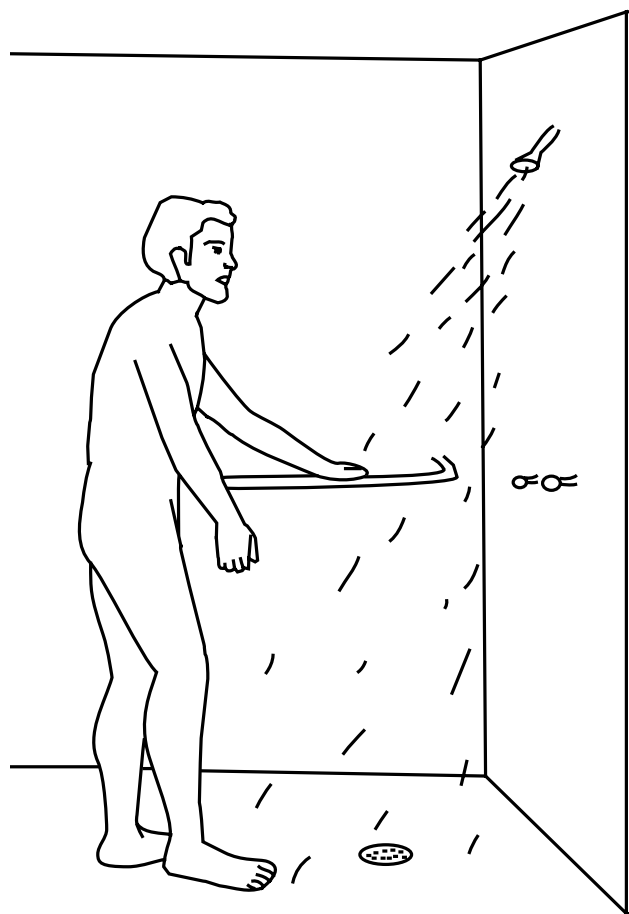

Fig. 41

A person with very poor balance should sit on a chair to bathe. A chair with a back and a strap across the person's hips or chest will help to prevent a fall during bathing. (fig. 42)



Fig. 42

If he has difficulty leaning side to side to wash his buttocks, cut out an opening in the seat. This will allow the individual (or the helping person) to wash the buttocks while he remains seated. (fig.43)

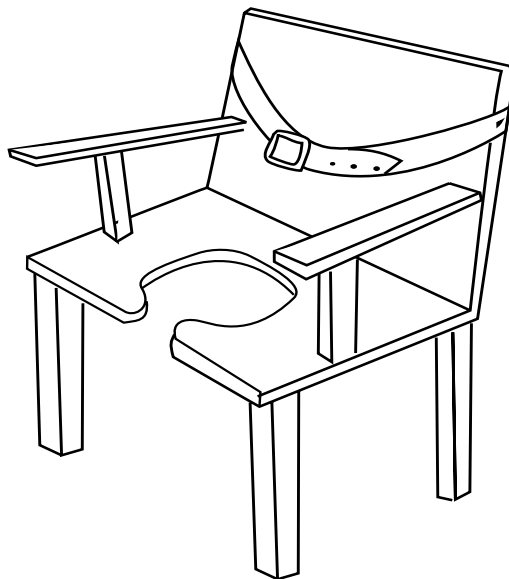

Fig. 43

If he is unable to grasp the wash cloth or soap, put a clean sock over his hand to allow him to wash by wiping with the covered hand. If the person does not use socks, two wash cloths can be sewn together to form a mitt. The soap can be put inside the sock or mitt, or rubbed on the outside when the person's hand is inside the sock or mitt. (fig. 44)

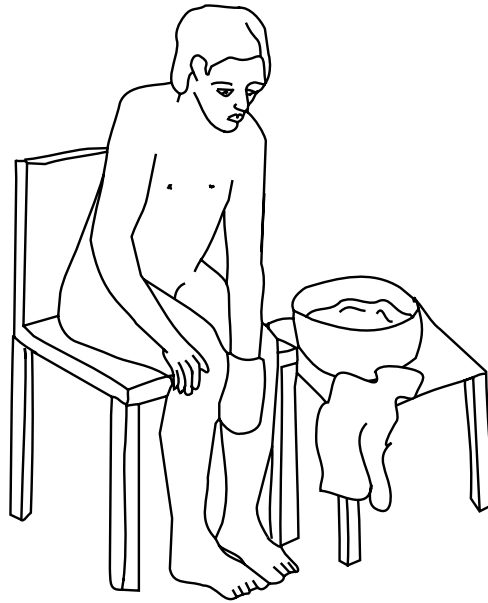

Fig. 44

If he is unable to reach to wash his feet or back, tie a wash cloth to a long stick. A stick can also be used with a towel to dry the feet and toes.

If the person needs to carry soap and other bathing items to a shower, a small bag may be used. (fig. 45)



Fig. 45

4.6 Bowel and Urine Management

How to Help People Who Have Difficulty With Using the Toilet

Both cognitive and physical problems from brain injury can cause a person to have difficulty with using the toilet.

Cognitive difficulties

She may not use the toilet because she is not aware or lacks sensation of a full bowel or bladder that needs to be emptied.

Brain injury may have decreased her desire to urinate or defecate in an acceptable manner. Because of brain injury, she may not be concerned about urinating in her clothing because the injury prevents her from caring about this problem.

This person will need assistance to relearn the social expectations about using the toilet. She will also need to relearn a routine for emptying her bladder and bowel.

Suggestions:

Regularly help her to change her soiled clothes and regularly help her to use the toilet or latrine. For example, take her to the toilet at 8 AM, 11 AM, 2 PM, 5 PM, and 8 PM.

Encourage her to clean her genitals and hands after using the toilet if she is able. If she does not appear to understand how to clean herself, demonstrate the motion that she should use.

Movement Difficulties

If movement problems make it difficult for her to use the family's usual toilet or latrine area, make a toilet chair for her to use.

The chair should have a back rest and arm supports. The seat should have a hole in the center where a bucket can be placed underneath.

A seatbelt or strap can be added to the seat for someone with poor sitting balance. (fig. 46)

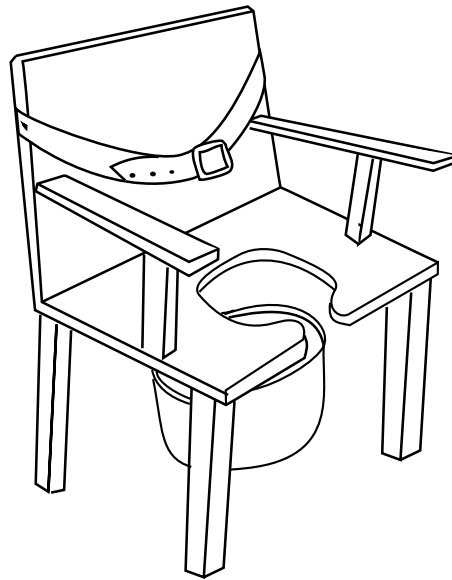

Fig. 46

A person with balance problems may need to hold on to a bar or post when sitting down and getting up from the toilet.

Attach the bar to a sturdy surface in front of or to the side of the toilet.

(fig. 47)

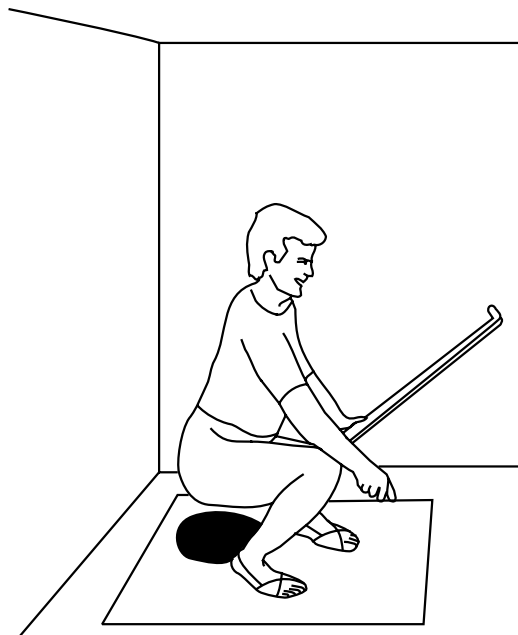

Fig. 47

The person with balance problems will be safer if she can hold on to a bar or post while cleaning herself after using the toilet.

It is important to remember that getting out of bed or out of a chair to use the toilet or latrine helps to develop the person's strength and balance. This will help to improve her ability to stand and walk.

4.7 Dressing

How to Help People Who Have Difficulty With Dressing

A person with brain injury may have poor memory or difficulty with learning:

The person should dress in the same way every day. This will improve his ability to learn the dressing routine. Keep clothing items located in the same place.

Do the tasks in the same order. For example, direct him to always use this order: underwear, pants, socks, shoes, shirt. (fig. 48)

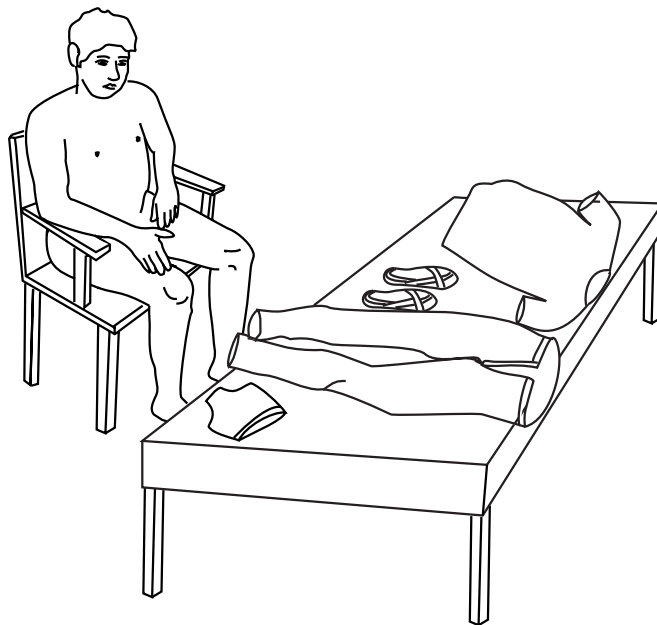

Fig. 48

To help the person who becomes confused when doing dressing tasks, or does not seem to understand the directions:

- Put out only the clothing pieces that are needed.
- If he stops dressing and seems confused about what to do next, or

does a step out of order, sit with him and give step-by-step directions. Wait until one step is finished before giving instructions for the next step.

- If he does not seem to understand, demonstrate what to do.
- If he is still unable to complete the particular dressing step, after instructions and demonstration, place your hand over his hand and move it in the direction needed to complete the step.

To help the person who seems weak and tired:

- Allow extra time to perform each task. Give rest breaks when needed. Encourage him to do as much as he is able to do, even if he can only do a little bit of each dressing task.

To help the person who has difficulty paying attention to what he is doing:

- Dress in a quiet room. Limit the number of people in the room. If conversation distracts him, do not talk to him while he is dressing.

To help the person who has difficulty getting started and completing a task, try using this list in order: (This method also helps the person who is unsure of what to do with an item)

- Tell the person what needs to be done.
- Give the information one step at a time.
- Point to each item.
- Demonstrate the action that should be done.
- Place your hand over his hand and move it through the action a few times.
- Then remove your hand and see if he will continue the action without assistance.

To help a person who has difficulty finding items on one side of his body, or taking care of one side of his body:

- Direct him to work with the neglected body part first. When dressing, put the neglected arm in the shirtsleeve first. When brushing hair, brush the neglected side first. Remind him of the side he neglects. Show him the limb and encourage him to massage that limb.

To help someone who has difficulty getting dressed because of difficulty with movement, weakness or balance:

- This person should dress from the position that offers the most stable balance. The person may be safer and more successful if he is seated for dressing tasks. Or he can lie down on his back for dressing.
- Put the weaker body part in the clothing first. Pullover shirts and tee shirts are much easier to manage than shirts with buttons or snap fasteners. Pants with elastic waistbands are easier to manage than pants that close with drawstrings, buttons or zippers.

Try these strategies with the person who is only able to use one hand to dress, or is very weak on one side of his body:

Putting on a pull-over shirt

- Position the shirt with the front of the shirt on his thighs. The neck opening should be near the knees.
- Open the bottom of the shirt and find the opening for the weaker arm.
- Place the weaker hand in the opening and push through the sleeve. If necessary, use the strong hand to place the weaker hand in the sleeve and pull the sleeve over the arm. Pull the sleeve material up past the elbow.
- Put the stronger arm in the sleeve and pull the shirt over the head. (Sometimes it helps to pull the shirt over the head first and then put the strong arm in the sleeve.)

Putting on a shirt with buttons

- Find the sleeve for the weaker arm. Position the sleeve so that it hangs down between the legs and then place the weaker arm in the sleeve. If necessary, use the strong hand to place the weaker hand in the sleeve.
- Pull the sleeve all the way up to the shoulder and around the back of the neck. Reach behind the head and pull the collar to the other shoulder.

Place the strong arm through the sleeve, and button. (figs.49 and 50)

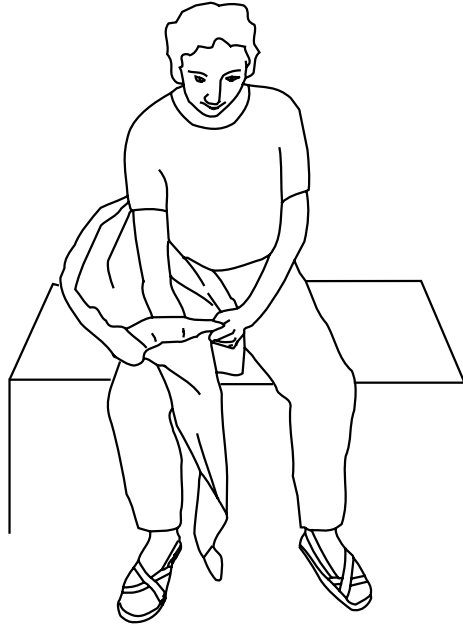

Fig. 49



Fig. 50

Putting on pants

- The person can dress while lying down. (The same procedure can be used when leaning against a wall or while propped in bed.)
- If the person is able, he should bring up his weaker leg and place the pant leg over the weaker foot. (fig. 51)

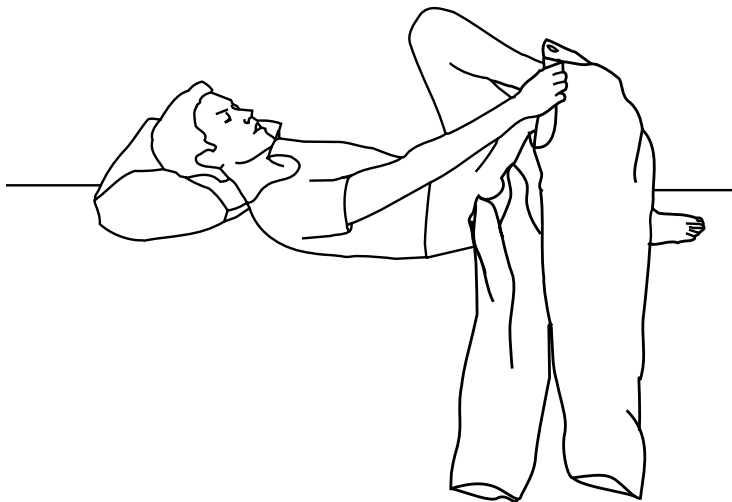

Fig. 51

- If he is unable to bring his foot up, try using a stick with a hook to bring his pants down to the weaker foot. (fig. 52)

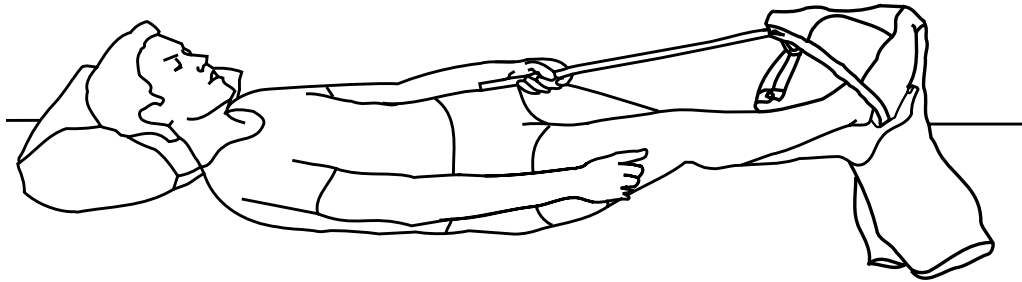

Fig. 52

- Put the other leg in the pants and use the stick to pull the pants up to where he can reach the pants by hand. Pull the pants up as far as possible.
- Then he can lift his buttocks off the bed and pull the pants over his hips. (fig. 53)

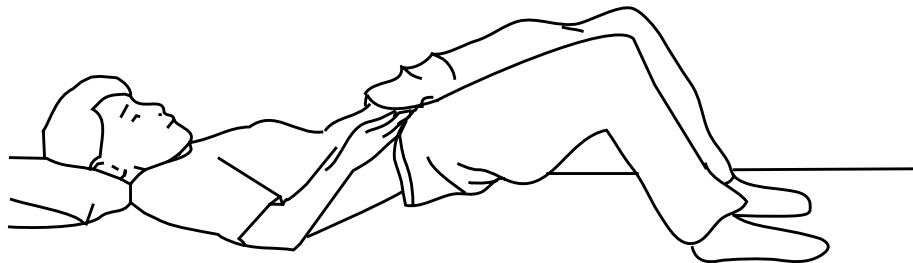

Fig. 53

If he is unable to use this method, try rolling side to side and gradually pulling pants over both hips.

Getting dressed while sitting in a chair

- If the person has difficulty bending over to reach his foot, he should cross his legs, placing the foot of the weaker leg over the opposite knee. (fig. 54) If he is unable to cross the leg, try propping up the foot to make it easier for him to reach.

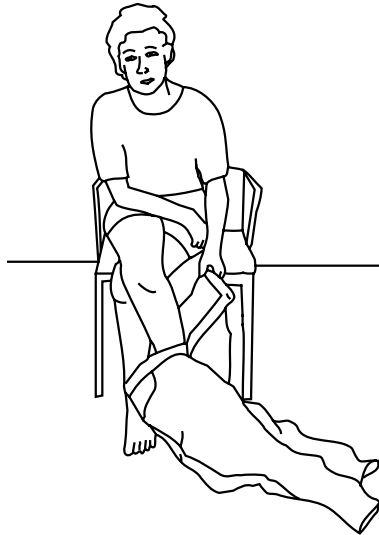

Fig. 54

- Or the person may try using a stick with a hook to place the pants over his feet. (fig. 55)

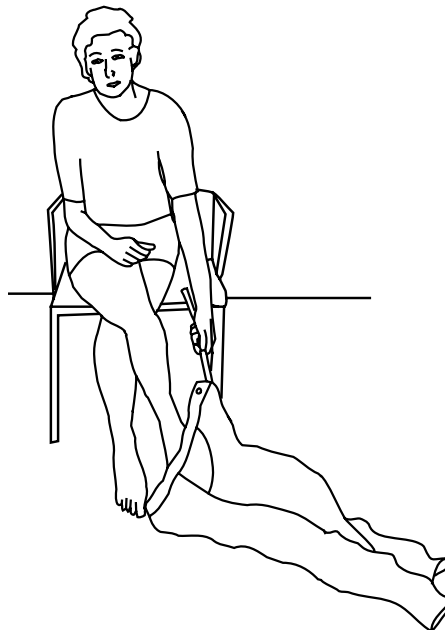

Fig. 55

- Pull pants up with the stick until they can be reached and pulled up by hand. Then he can stand up and pull the pants up all the way. Give him assistance to adjust his pants and maintain his balance if this is needed.

Putting on socks with one hand

- Bring the fingers together and push the hand through the sock. Open the sock by spreading the fingers apart. Pull the sock over the toes. Take the hand out and pull up the sock. (fig. 56 a, b)

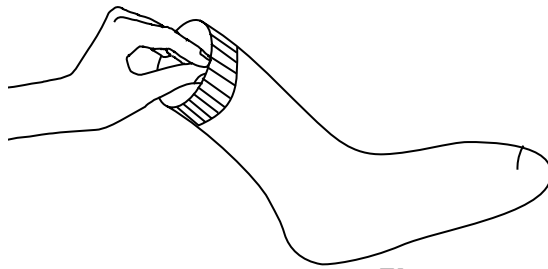

Fig. 56a

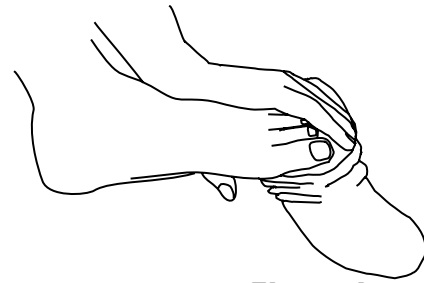

Fig. 56b

Putting on Shoes

If the person is unable to reach his feet, add a handle to a shoehorn to make it easier to slip his foot into the shoe. If a shoehorn is unavailable, you can carve a piece of wood to fit the curve of the person's heel.

One-handed shoe tying technique (fig. 57)

1. Tie a knot in one end of the shoelace. Thread the unknotted end up through the hole nearest the toe of the shoe, on the left side.
2. Take the lace across the tongue of the shoe and up through the hole on the opposite side of the shoe.
3. Continue to thread the lace across the tongue and up through each next hole on the opposite side until you thread it through the last hole.
4. Thread the end of the lace between the last two holes, pointing it toward the ankle. Do not pull it tight. Leave a small loop of the lace.
5. Make a second loop with some of the remaining lace. Do not use the end of the lace.

6. Thread this second loop through the first loop, pointing the loop toward the ankle. Pull the loop tight.

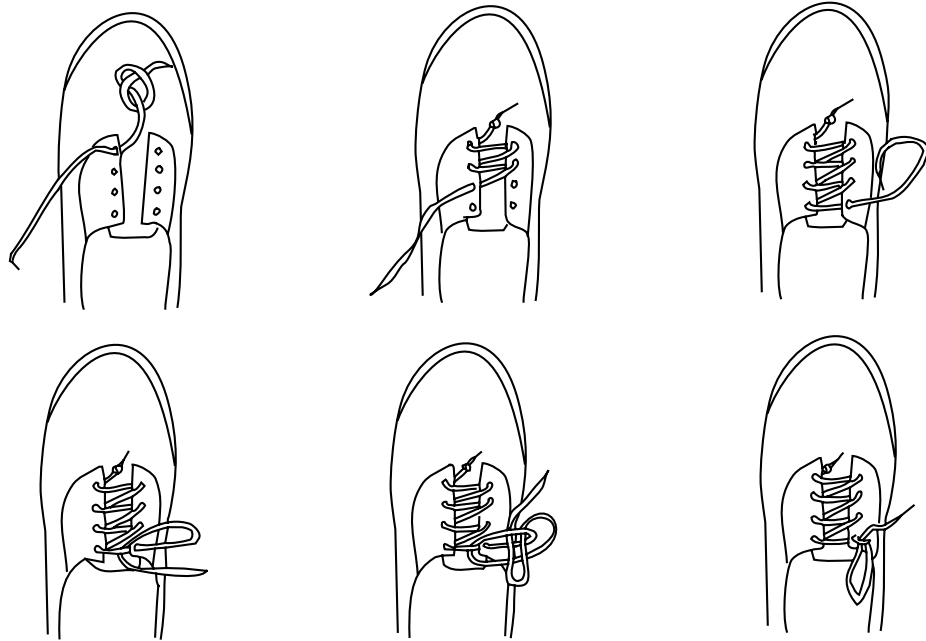

Fig. 57

4.8 Walking

How to Help People Who Have Difficulty Walking

A person with brain injury must often relearn the process of standing up, keeping balance and walking. As in all other areas of retraining, the person who is doing the training must consider both cognitive and physical difficulties.

- She may not remember how to do the movements.
- The legs may be too weak, stiff or deformed to support her weight
- She may have uncontrollable leg movements.

She must learn to stand and balance before she can learn how to walk. Begin with training her to stand up from a sitting position in a chair or on the floor.

4.8.1 How to Train a Person to Stand Up From a Chair

- Tell her in simple terms what you are going to do.
- Make sure her feet are positioned flat on the floor. (fig. 58)

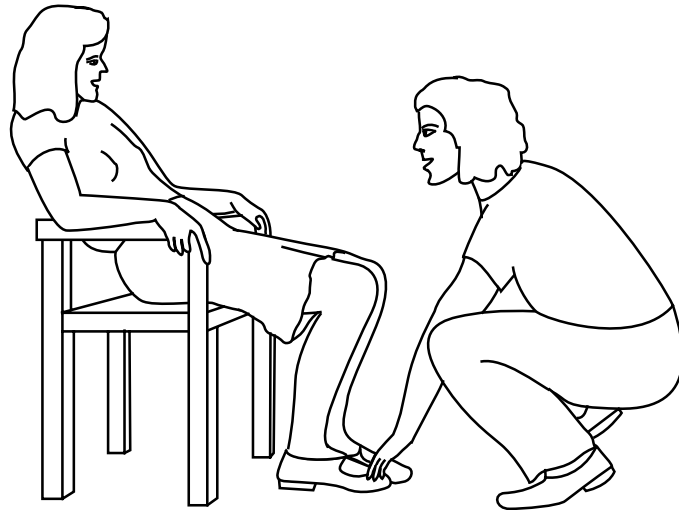

Fig. 58

- Ask her to bring her buttocks to the edge of the seat. (fig. 59)
- Ask her to lean forward, so that her head is directly above her toes. (fig. 60)

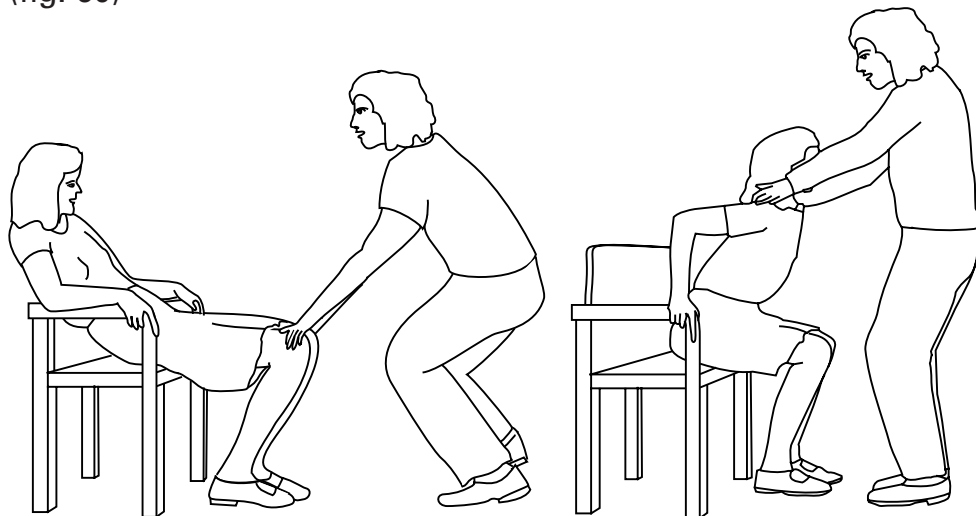

Fig. 59

Fig. 60

- She may need one or two people to help her stand up. If two people are helping, one helper stands on either side of the person and places one hand under one of her arms, with the other hand around her back. (fig 61)



Fig. 61

- If only one person is helping, the helper may need to stand on the person's weaker side and support the weaker leg while guiding the person to standing.
- The helper may also choose to stand on the person's stronger side and guide the person to push up to a standing position. (fig 62)

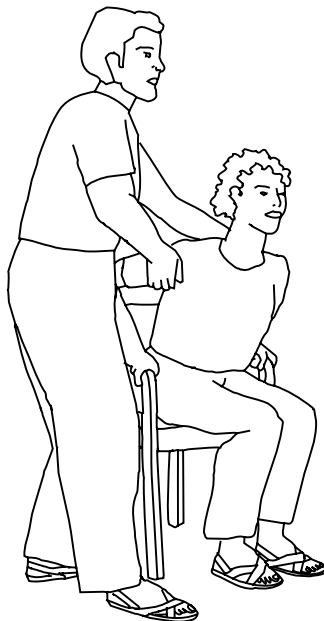

Fig. 62

- The helper may need to stand in front of the person and assist by pulling up from under both arms. (fig 63)

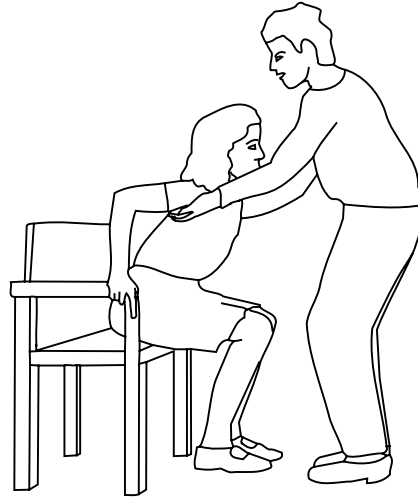

Fig. 63

- Helping the person rock back and forth gently to the count of "1 – 2 – 3" will help both the injured person and the helper to lift up at the same time.
- Remind the person to push up with her legs. Telling her to lean forward and to look up may make standing up easier.

4.8.2 How to Teach a Person to Stand From a Sitting Position on the Floor

First Teaching Exercise

- The person may be able to stand up by using a wall with wooden or metal bars for support. Attach three strong pieces of wood to the wall. The lowest piece should be at her eye level when she is sitting on the ground. (fig. 64)

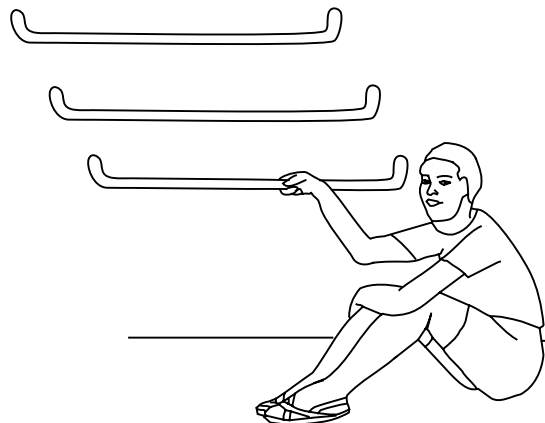

Fig. 64

- Tell the person to face the wall and use her hands to pull up on the bars.
- A helping person may need to stand behind the person and assist by lifting her at the waist. She may need to practice this exercise many times.

Second Teaching Exercise

- The person sits on the floor with knees bent.
- One helper stands on either side of the person, bending at the knees and preparing to lift the person beneath each arm. (fig. 65)



Fig. 65

- Each helper holds the person under one arm with one hand and supports the person's forearm or hand.
- The helpers then lean the person forward and help her to stand up, making sure that her feet stay firmly on the floor.

Third Teaching Exercise

- The person sits on the floor with knees bent and feet on the floor.

- One helper stands behind the person and reaches under her arms to grasp her forearms in front of her body. (fig. 66a)
- The helper then stands up and lifts the person forward, making sure that the person's feet stay firmly on the floor. (fig. 66b)



Fig. 66a

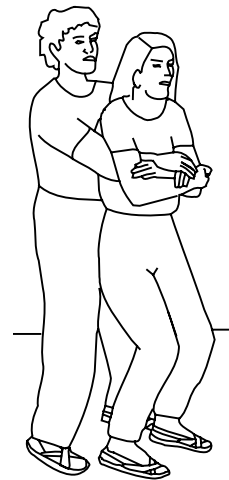

Fig. 66b

Fourth Teaching Exercise

- The person kneels facing a chair or low table. (fig. 67a)

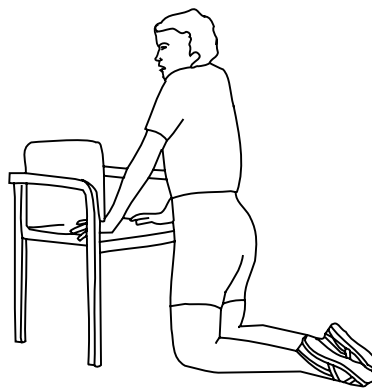

Fig. 67a

- The person uses the chair to lean forward while he brings one leg forward and places the foot flat on the floor. The person then uses the support of the chair to push into a standing position. (figs. 67b, 67c)

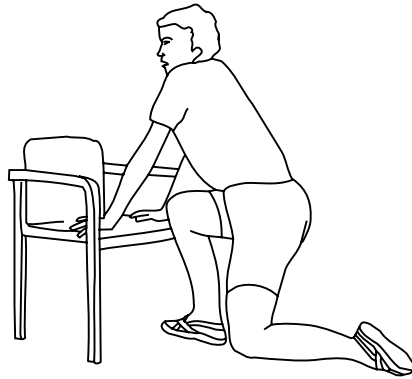

Fig. 67b



Fig. 67c

4.8.3 Keeping Balanced While Standing Up

The person with a brain injury may have been in bed for a long time. The longer she has been in bed, the harder it will be for her to stand and walk. Her joints may be stiff and painful. She may have trouble keeping balance for many reasons:

- Her legs may not be strong enough to hold her upright.
- She may become dizzy when she tries to stand.
- Her legs and feet may not straighten out.

The person may not be able to stand for very long on the first attempts. Allow her to become used to the new position by moving slowly. If she has been lying down, allow her to sit for several minutes before helping her to stand. This will prevent her from becoming dizzy.

The following exercises can be used to train balance:

The person stands with the support of two helpers.

- Each helper supports the person with one arm around her back and the other arm in front, holding on to her hand or forearm. (fig. 68)

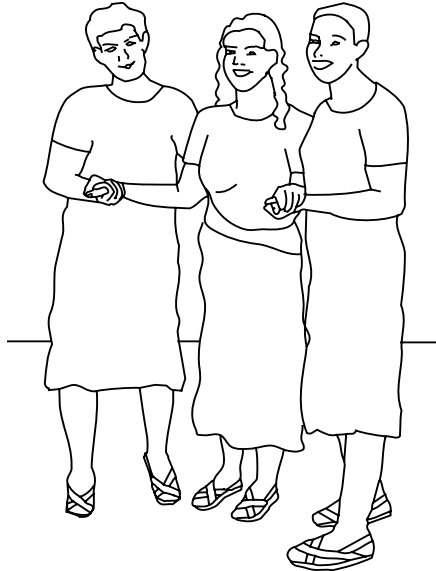

Fig. 68

The person stands with the support of one helper.

- The helper stands on her weaker side. The helper places one arm around her back and the other arm in front, holding onto her hand or forearm. (fig. 69)

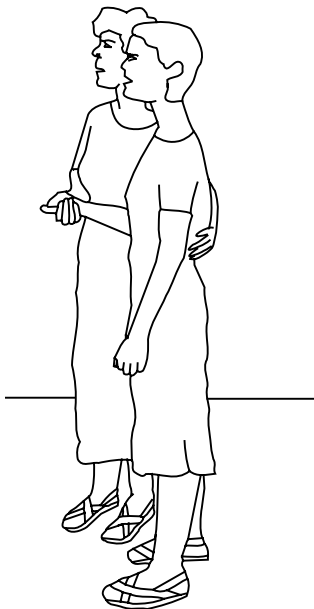

Fig. 69

The person stands in front of a high table.

- She leans on the table with her arms on the table to support her body weight. (fig. 70)

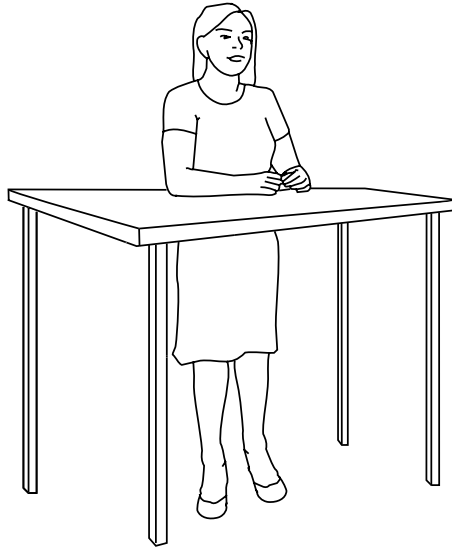

Fig. 70

The person may need help to keep her knees straight when she stands. She will need to practice standing every day. When she begins to stand, she can use a table or chair for support. When she can stand for longer periods of time, ask her to lean less on the chair or table. *The goal is for her to become able to stand without support.*

4.8.4 Exercises to Help Prepare for Walking

Check to see if the person can stand without support. Tell him to move one foot forward and then back. (fig. 71)

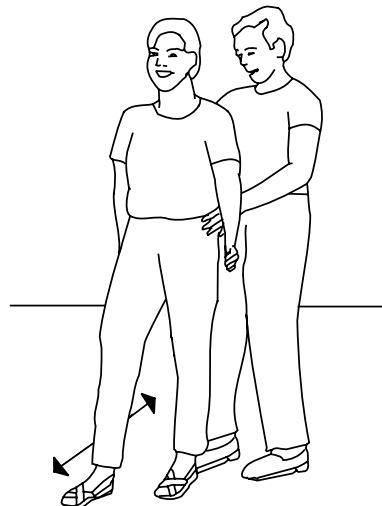

Fig. 71

If he can stand without support, ask him to move his body from side to side. The helper must be ready to catch him if he begins to fall. (fig. 72a, 72b)

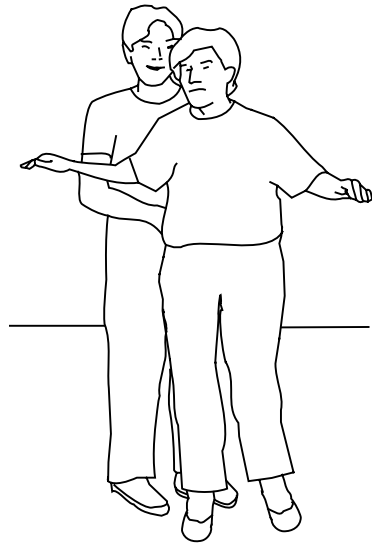

Fig. 72a

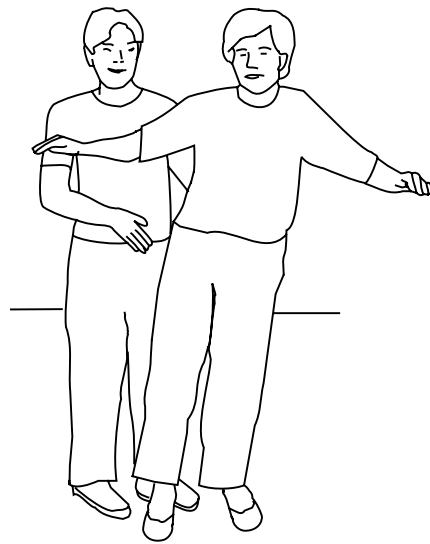

Fig. 72b

Training a person to walk

If he cannot stand by himself, he will need support to stand and walk. Support can come from a helper or from use of equipment such as crutches. A person can be trained either with a helper or by leaning on a crutch for support.

Teaching a person to walk with the help of two people

- One helper stands on either side of the person, holding her arms in front and supporting with the other arm around her back. (fig. 73)

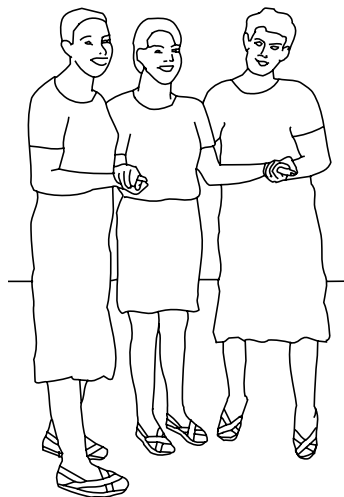

Fig. 73

- The person may need a brace to keep one or both of her legs straight when standing. The brace should be put on before the person stands up. Once she is steady in standing, help her shift her weight to one foot and then to step forward with the other foot.
- She may need help to step forward with one foot while keeping her balance on the other leg.
- Allow the person to lean on the hands of both helpers with her own hands.
- Remind her to keep her head up and look forward as she is walking. (Looking down at the ground makes it difficult to walk properly.)
- Only one helper should give the person directions. If both helpers are talking at the same time, the person with brain injury may become confused.

Teaching a person to walk with the help of one person

First Teaching Exercise

- Stand on the person's weaker side with one arm supporting her hand in front and the other arm around her back. (fig.74)

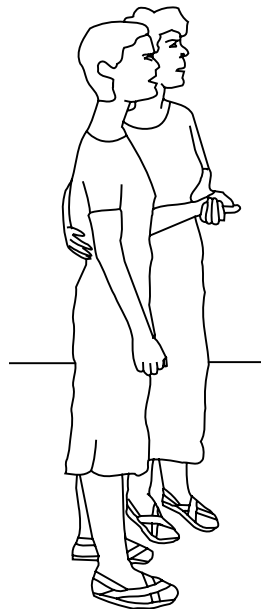

Fig. 74

- Help her to shift her weight to one side and step forward with the other foot. The helper can assist by resting a hand on her hip and

guiding her to shift her weight to the opposite leg. Once her weight is shifted, tell her to step forward with the other foot.

- If the person still cannot move her weaker leg forward, the helper will need to assist by pushing the weaker leg and foot forward.

Second Teaching Exercise-Teaching a person to walk by leaning on a walking device for support

- The person must be able to use both hands in order to use a walking device (sometimes called a “walker”).
- A walker can be made by using pieces of wood to build a frame for the person to lean on.
- The handles of walker should be nearly the same height as the top of the person’s hips. When the person leans on the handles, his elbows should be slightly bent. (Fig. 75)
- The person holds the walker with both hands. The walker will help him keep balance, but he may still need the assistance of a helper. The helper should stand on the person’s weaker side or behind him and the walker.

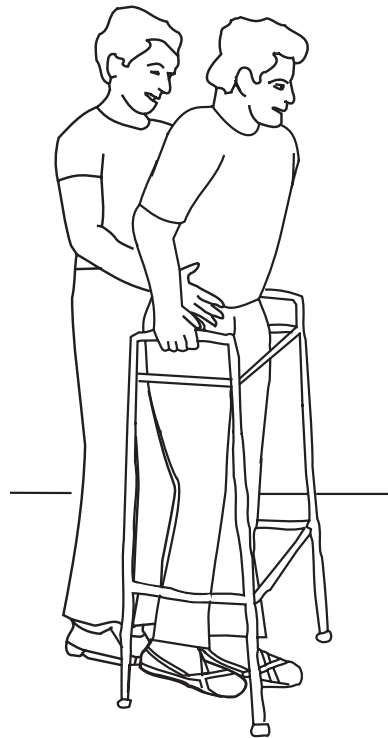

Fig. 75

- Ask the person to move the walker forward with both hands. Make sure all four legs of the device are on the ground before the person steps forward.
- Ask him to step forward first with one foot, then with the other foot. Make sure that his feet remain in the boundaries of the walker's frame. He should not step too far forward. This could cause him to lose balance. Ask the person to keep his head up and to look forward when walking.
- Keep the directions very simple. Do not give many directions at one time. This can be confusing.
- Allow him to stand and get his balance before taking any steps forward.

Walking is very tiring for someone who has not walked in a long time. Walk short distances at first and allow the person to rest often.

4.9 Speaking

How to Help People Who Have Difficulty Speaking

A brain injury may cause difficulties in a person's ability to understand words, to use words, to express ideas, and to speak clearly.

4.9.1 Problems With Understanding and Expressing Language

The problem of understanding and communicating spoken or written language is called *aphasia*. After brain injury, a person may have difficulty both with comprehending the spoken or written words of other people and with forming her own words to express her thoughts.

She may not be able to follow any commands or instructions.

She may follow only parts of commands.

She may be able to follow a simple (one-step) instruction, but not longer instructions.

She may not be able to understand gestures or written words.

She may not understand humor.

Some persons may seem to understand language but are unable to form the words to express their thoughts. The person is often at least somewhat aware that she is having this difficulty. She may become

quite frustrated or agitated when she cannot communicate words that others can understand.

She may substitute words or sounds (saying cup for spoon or saying "tup" for cup).

She may leave out words in a sentence.

She may have difficulty finding the right word for the names of common objects or actions.

She may struggle to produce a word, and make extra movements of the lips and tongue that do not produce the intended sound or word.

Other persons may speak as though they are having a conversation and be quite unaware that their words make no sense.

A person may use nonsense words.

She may put sentences together that are disorganized or not related.

She may talk and talk and not give other persons a chance to talk.

Strategies to help a person understand

- Make sure you have the person's attention before speaking. Say her name and make sure that she is looking at you.
- Speak slowly.
- Try to use the simplest words that can communicate your message.
- Use short sentences. Repeat your sentence if necessary.
- Use pictures, gestures and demonstrations to help her to understand your words.

Strategies to help the person with aphasia to speak the correct words

- Help her to practice words by naming objects around the house.
- Encourage her to use gestures.
- Ask her to describe what an object looks like or what it is used for.
- Even if a person leaves out words in a sentence, she may be able to communicate her message. Repeat the full sentence back to her so she can hear the words that she did not include in the sentence.
- If she is unable to say a word that she wants to say, ask her to watch and listen to you as you say the word. Then ask her to repeat the word.
- Ask her to practice words and phrases that are most often needed. For example, "I have pain." "I want a drink".

- If she talks too much, clearly tell her when she needs to be quiet and listen to what other people are saying. Ask her to be quiet while you are speaking to her.

Other ways of helping the person with aphasia to communicate:

- If you are not sure what she is trying to say, ask questions that she can answer with YES or NO.
- Encourage her to use gestures or to point at pictures that help express her basic needs. (fig. 76)

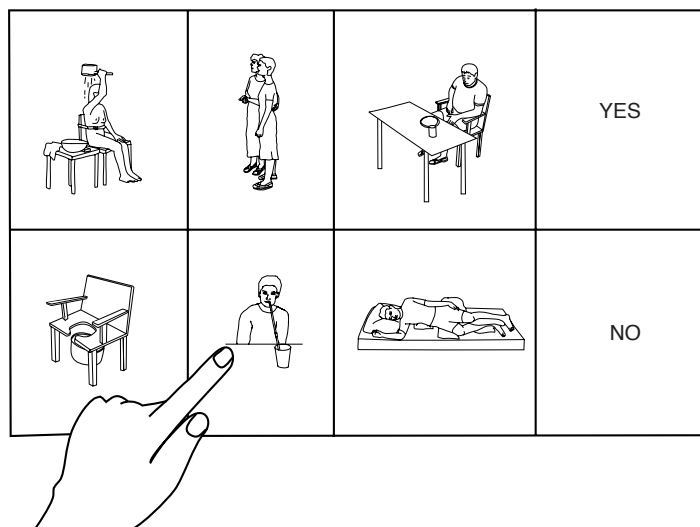

Fig. 76

4.9.2 Problems in Speaking Clearly

The person may have difficulty with speech because she cannot correctly move the muscles of her mouth and tongue. This condition is called *dysarthria*.

- She may have slurred speech sounds.
- She may speak too fast, too slow or too softly.
- The voice may have a weak, strained or hoarse quality.

Some ways to improve speaking:

- If she talks too fast, ask her to say one word at a time. You may need to help her by having her tap her fingers on her leg for each word that she wants to say. Tapping helps to create a slow rhythm.
- If a person talks too slowly, give her time to talk. This may be the only way she can make herself understood.
- If her voice is very soft or weak, she should take a deep breath before starting to talk.

If sounds in words are slurred or not precise, the person needs to do exercises to strengthen and increase the movements of her lips and tongue. For example:

Smile Exercise

- Smile. Show the upper and lower teeth and gums in a wide grin.
- Clench the teeth gently. Relax the neck. Do not squint.
- This exercise strengthens lips and cheeks and improves the ability to move those muscles. (fig. 77)

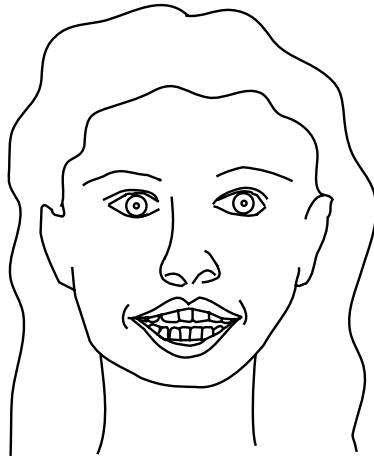

Fig. 77

Kissing Exercise

- Purse lips and blow a kiss. Close lips tightly and make the sound: *mum mum mum*. Also practice the sounds: *be be be be be* and *pe pe pe pe pe*.
- This exercise strengthens lip muscles and helps the formation of speech sounds. (fig. 78)

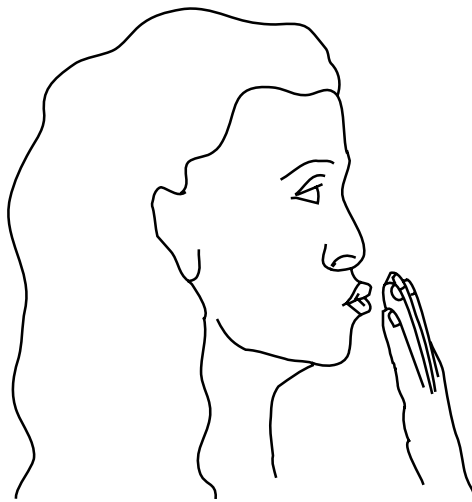

Fig. 78

Tongue Exercises:

- Stick out the tongue at the right corner of the mouth. Hold the tongue in that position for ten seconds. (fig. 79a)
- Switch to the left corner of the mouth and hold the tongue in that position for ten seconds. (fig. 79b)
- Now, stick the tongue out straight and hold in that position for ten seconds.(fig. 79c)
- This exercise stretches and strengthens the back and sides of the tongue muscles and improves tongue movement.

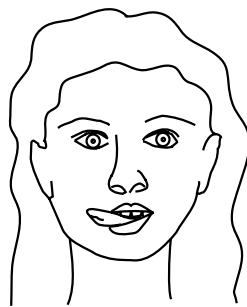

Fig. 79a

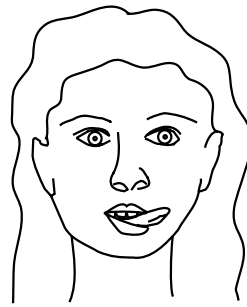

Fig. 79b

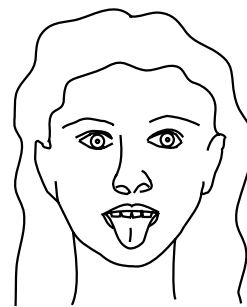

Fig. 79c

If the person is able to read, she may be able to spell out a message. A Letter Board can be made by writing the letters of the alphabet on paper or cardboard.

- Start by asking her to point to the letters to spell her name to see if she is able to use this method.
- Then ask her to point to the letters to spell words. Remember that a person who has difficulty seeing or moving may not be able to use this method.

4.10 Reading and Writing

How to Help people Who Have Difficulty Reading and Writing

Reading

In order to know if there are changes in a person's ability to read, a helping person must first know how well the person was able to read before the injury.

With this knowledge, the helper can observe the person's current ability or difficulty with reading. For example:

- Can he read signs that are posted in his community?
- Does he follow written directions accurately?
- Does he correctly understand notes that you leave for him?
- Does he complain of headache or double vision when he reads?
- Can he answer simple written questions?

A helper should learn what reading tasks are required of the person at this time. The helper should focus work on the reading tasks that the person most needs. *For example, does he need to read:*

- Signs
- Recipes
- Instructions
- Letters
- Books
- Newspapers

Strategies to help the person with reading:

- Ask him to read single words or short phrases and gradually increase the number of words to be read.
- Instruct him to take his finger and move it from one word to the next.
- If he has double vision, cover one eye with a patch.
- If he has difficulty concentrating, provide a quiet place for reading.

Writing

The helper should learn the answers to these questions about the person's writing ability:

- Can he write his name and address?
- Can he write numbers?
- Can he write single words?
- Can he write a note or simple correspondence?

Some writing difficulties may include:

- He may reverse letters or leave out letters or entire words.
- He may add extra letters in the word.

- The writing may not be legible.
- The writing may be poorly organized on the page.

Some strategies to help the person with writing include:

- Encourage the person to copy his name, address and familiar words on a practice page.
- Draw lines on the practice page to make the words easier to read. (fig. 80)

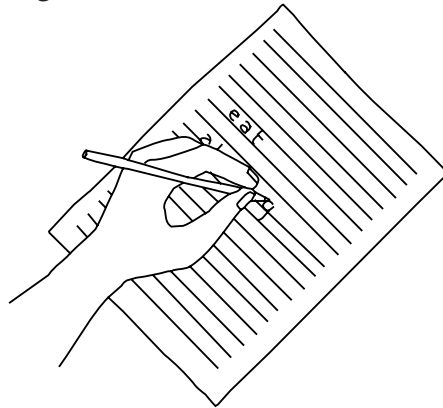

Fig. 80

4.11 Homemaking

How to Help People Who Have Difficulty With Homemaking Activities

A person who has had a brain injury may be helped to relearn many of the everyday activities that she performed in the home before the injury. Participation in these activities can help the person to feel needed by the family. It will also help to improve her strength and her ability to think and solve problems.

The person and her family members may need to meet together to decide on the tasks that she will start to do. It is important for everyone to agree on the choice of tasks and on the parts of the task that the injured person is to relearn. If there is no agreement, some family members may allow the person to try to do the task, but others will do the task for her. This can cause the person with brain injury to become confused or frustrated. Or she may stop trying to do the task.

Relearning should begin with a task that the person is likely to be able to do – even if she can do only a small part of the task.

- Choose a short, simple task or one part of a larger task that can be divided into different steps. For example, "cooking dinner" is a

routine that is made up of many possible small tasks and steps. Start by having the person work to relearn one of the small tasks involved in cooking dinner, such as cooking the rice.

- Once the person is able to successfully perform one step of the task, add another step until all the steps of the task are accomplished.

If she forgets the steps of the task or the order of the steps, write the steps of the task on separate pieces of paper or in the form of a list. The steps of the task should be short and simple. For example:

1. Find a pot for cooking rice.
2. Pour water into the pot.
3. Wash the rice.
4. Put 2 scoops of rice into the pot.
5. Add water to the correct level inside the pot.

Breaking larger tasks into smaller ones and practicing them frequently will make the tasks easier to learn.

Combining individual tasks into routines

A person may become successful in performing small or simple tasks, one at a time but show difficulty when she needs to combine and coordinate the small tasks into a larger routine. For example, the person may learn to successfully complete the task of cooking rice, but be unable to also correctly cook all of the other dishes that accompany the rice. Or she may cook the individual dishes correctly but not coordinate the cooking times, so that the dishes are not ready to be served at the same time.

Combining individual tasks into daily routines requires a high level of cognitive ability. It requires the ability to plan, organize and remember all of the separate tasks that make up a routine. The person must also be able to evaluate if she has completed the routine in an acceptable way, or if improvement is needed.

Homemaking activities offer excellent opportunities for the person with brain injury to work on relearning the skills needed to manage many kinds of daily routines.

Strategies to help a person to relearn routines:

- The helper should encourage the person with brain injury to practice routines, just as she practiced the steps of individual tasks.

- The helper may assist her to make a written checklist of tasks that make up the routine. The tasks can be checked off when they are completed. (If the person has a very poor memory, the helper may need to remind her to check off the task when it is completed and then to move on to the next task.)

The following is an example of a checklist for a daily homemaking routine:

1. Wash laundry
2. Hang clothes to dry
3. Sweep floors
4. Cook lunch.....

The person may need to keep the list where she can easily find it at any time. The list may be kept in a pocket. Or the list may be kept in one central place such as on the wall above the bed. It may also be helpful to write activities on a calendar or to decide that certain activities will be done on specific days and times. (fig. 81)

For Example:

Monday: do laundry

- 10:00 AM wash clothes
- 11:00 AM hang clothes to dry
- 5:00 PM fold clothes

Tuesday: purchase food

- 10:00 AM leave house and go to market
- 12:00 Noon return home and put food in storage space ..

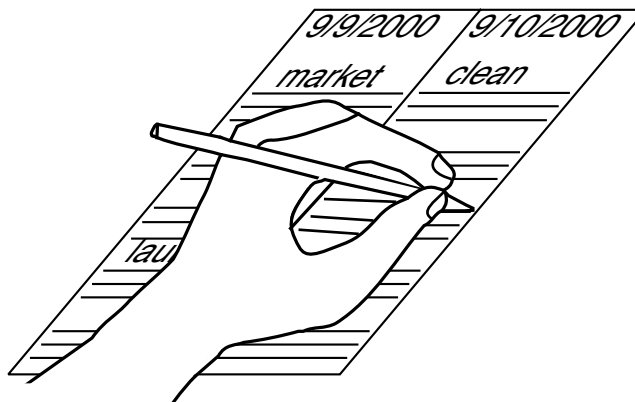

Fig. 81

4.11.1 Homemaking Safety

Many homemaking tasks can be dangerous if not done safely. As discussed in Section 3.1.2 Making the Home a Safe Place, the person who performs the task in an unsafe manner, risks injury to herself and also to other family members.

A person with brain injury may need help to relearn how to safely perform homemaking tasks. Another person will need to remain near by, to assist or guide her while she is re-learning the tasks and routines.

The following guides can increase safe participation in homemaking tasks:

- If a person has poor balance or uses a walker, remove all small floor rugs that could cause her to trip and fall.
- If she has poor balance, she should perform tasks from a sitting position. Items that she needs should be placed within her reach. For example, she may fold laundry or do food preparation while sitting.
- A person who is weak or tires easily should take rest breaks during the task. It may even be necessary for her to take a few days to complete one task.

The person should not be left alone to do homemaking tasks until she can clearly perform the task safely. *The following are guides that helpers can use to decide if a person is safe enough to perform tasks on her own:*

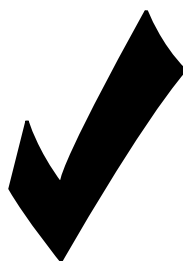

- She is able to maintain her balance.
- She is able to start the task.
- She is able to pay attention to what she is doing throughout the task.

- She is able to remember the steps of the task, or she is able to follow written or spoken directions
- She is able to decide what to do if there is a problem
- She is able to follow the rules for safely doing the task
- She knows when the task is completed
- She knows if the task has been done correctly or incorrectly

4.12 School Work

How to Help a Student With Brain Injury to Return to School

Unfortunately, throughout the world there are still many communities where schools hesitate to accept students with disabilities. Community resources may be limited and there may be the assumption that students with disabilities do not benefit from formal education as much as other students.

The World Health Organization (WHO) strongly advocates the right to education for all children of school age. An important task for the Mid-Level Rehabilitation Worker is to help community members understand the importance of education for students who have disabilities, and to assist efforts toward improved school opportunities for these students.

The student who has had a brain injury needs help to strengthen his ability to learn and compensate for physical or mental limitations. The following recommendations are written especially for teachers, to help prepare for teaching the student with brain injury.

4.12.1 Preparing for the Student With Brain Injury

There are no strict rules for when a student should return to school after a brain injury. The student is ready to be considered for school when his medical needs and physical or cognitive difficulties are manageable in the school setting.

The teacher or school administrator will need information about all special needs and requirements. The family may be able to provide much of the information, but information from the student's doctor or medical care center may also be needed, especially information about required medicines or other treatments.

Medicines

What kinds of medicines are needed? What times must the student take medicine? What help will the student need with taking the medicines? Must the teacher watch for any problem effects of the medicine?

An appropriate plan must be in place for managing the student's medicines. Family members may need to assist or take responsibility for giving medicines.

Fits (Seizures)

Does the student have fits? What happens when the student has a fit? What must the teacher or others do to help when he has a fit?

The teacher and others who work with the student will need to have training in what to do if the student has a fit. Classmates will also need information so they are not afraid and can assist if necessary.

Physical impairments

Does the student have difficulty walking, keeping balance, eating or using the toilet? Does he need assistance from a helper for any of these activities? Does the student have difficulty with vision or hearing? Does he need a wheelchair or other equipment? Does he need time to rest during the day?

The teacher needs to clearly know what physical help the student requires. Then the teacher can work with the family to make a plan for providing the needed assistance. It is not realistic to expect the teacher to handle all of a student's physical care needs. Help may be needed from a family member or volunteer from the community so that the student's physical needs are met without disrupting classroom instruction.

Communications

Does he have difficulty speaking or difficulty understanding the words of others? How does the family communicate with him at home?

The student should be able to communicate basic needs and respond to classroom instruction in some manner (although not necessarily through speech).

Memory, Attention and Concentration

Does he have difficulty remembering new information? Can he remember information that he heard yesterday? Is the student able to

pay attention to instructions? Can he concentrate on tasks, or is he easily distracted?

The student should be able to follow simple directions. If he cannot remember tasks or assignments, he will require a system for keeping information that he needs in order to complete school tasks. The student with brain injury should be able to pay attention to a task for at least 10 to 15 minutes. He should be able to tolerate ordinary classroom noise and activity.

Behavior

Does the student have any behavior problems since the brain injury? Does he have difficulty controlling anger? Does he ever hit or try to hurt other people? Does he do or say embarrassing things? What does the family do when the student has problem behavior at home?

He should be able to participate in a group of two or more students without becoming agitated or upset. A family member or other helper will be needed to help with the student who must occasionally be removed from the classroom because of agitation or problem behavior.

Information gathered through these questions will assist the teacher to understand the main ways that a brain injury affects a student's ability to learn and participate in classroom instruction. The teacher will use the information to develop an educational plan and determine what kinds of assistance will be needed in the classroom.

The teacher may need to ask family members or other helpers to provide assistance during each school day, especially if the student has physical care needs or behavior problems.

4.12.2 Suggestions for Helping the Student With Brain Injury to Learn and Perform Tasks

Problems with attention and concentration:

Reduce room noise or allow the student to use earplugs to reduce distraction. The student may need to sit apart from classmates when working on an assignment.

Increase his ability to pay attention by having him sit at the front of the class, away from windows or doors.

Before giving task instructions, ask the student a direct question to determine if he is listening. Then ask him to repeat the instructions in his own words so you can be sure he understands.

Teach the student to regularly ask himself questions such as:
Am I paying attention? What is the teacher saying?

Explore different ways of reminding him to continue with the task. Students with brain injury almost always need reminders to keep working. Some may need to have directions constantly repeated. Others may need only an occasional reminding word. Some may respond to direction from a simple gesture.

Learn the student's usual span of attention. Try to break school assignments up into smaller tasks that can be done within his span of attention.

Praise the student for his continued work at the task.

Problems with memory and learning:

Teach the student to take notes about assignments.

Repeat information and review educational materials.

Break assignments down into the most basic parts. Each day, the teacher should review the material taught on the previous day. After review, the teacher can add the new material for the current day.

Teach the student a way to organize information and materials so that he can easily find them each day. One way is to teach him to keep notes for each subject on separate pieces of paper or in separate notebooks.

Combine lectures with pictures and models (fig. 82)

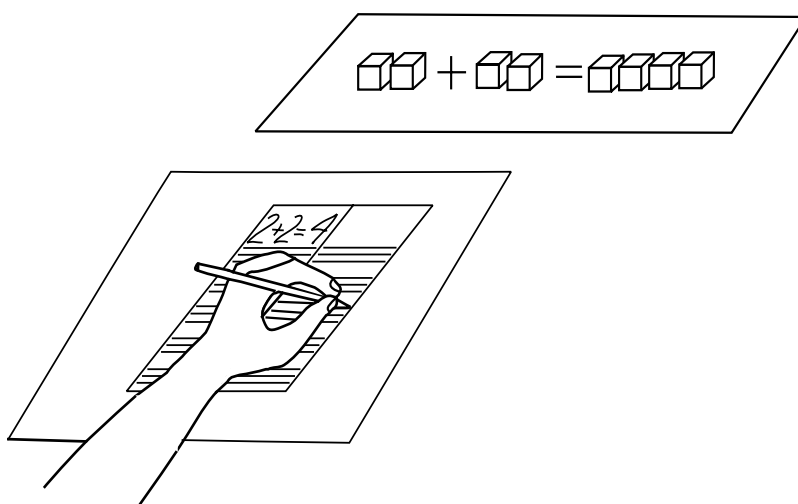

Fig. 82

Problems with thinking and reasoning:

Allow the student additional time to think about the day's new information and to complete classroom tasks.

Teach the student to make an outline of the assignment so he can more easily follow a lecture or instructions.

Teach the student to make a list of school tasks, and to check off each task when it is completed.

Teach the student to use notebooks, calendars and schedules.

Teach the student to identify real-life problems and find solutions to those problems.

Guide him in the steps that are involved in problem solving:

1. Identify the problem.
2. List important information about the problem.
3. Identify the possible solutions and select the best solution.
4. Make an action plan for solving the problem.

Praise the student for continued work at the educational task.

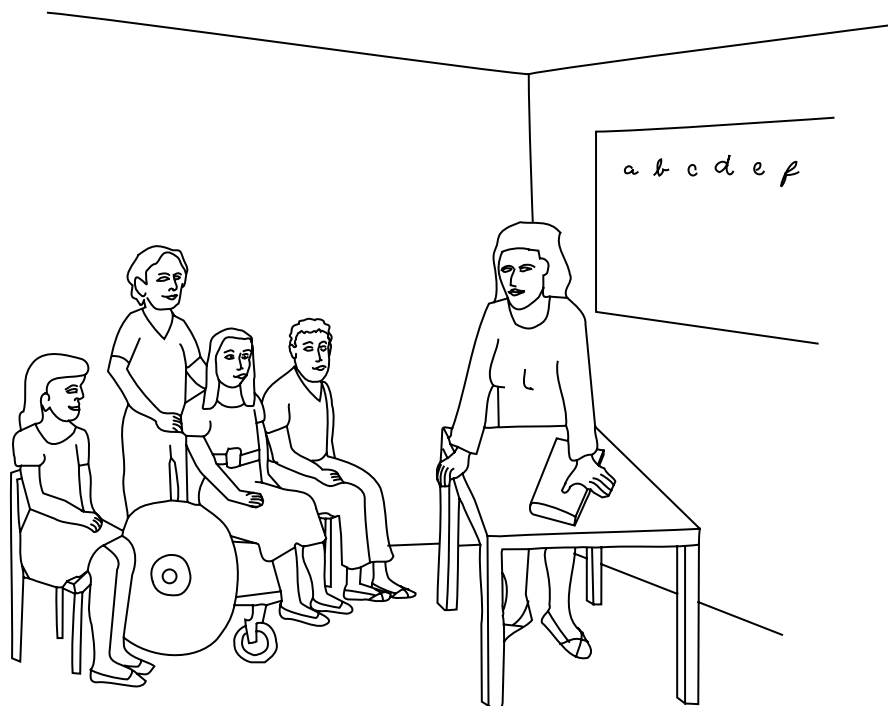

4.12.3 Reviewing and Changing the Educational Plan

The student with brain injury is likely to change in abilities and in needs for assistance as he continues to recover from the injury. As the student improves, his educational plan will also change. It will be important for the teacher to meet with the family at regular time intervals to review the student's progress in his educational program. Whenever possible, the student should also participate in this review. The teacher and family may find that the student needs more assistance or different kinds of assistance. Or the student may be ready for higher level assignments and challenges.

As the student's educational plan continues to develop, the most important question will be: How can this student be best prepared for his adult years, so that he may become a functional and active member of the community?

Additional materials for teachers, family and community members:

The WHO Manual, *Training in the Community for People With Disabilities, "Guide for School Teachers"*, provides information about how to teach children who are born with a disability or who develop a disability at an early age. *"Training package 27, for a family member of a child with a disability – Schooling"* gives additional information and guidance for the family.

4.13 Rehabilitation for Work

How to Help a Person Return to Work After a Brain Injury

The WHO manual, *Training in the Community for People With Disabilities, "Training Package 30, for a family member of a person with disability – Job Placement"*, emphasises the importance of work for persons with disability. The training package includes suggestions for types of jobs that may be available in the community and basic recommendations for job training.

The material in this section will focus on a model of work rehabilitation that has been found useful for persons with brain injury. This model is called Supported Employment because returning the person to work involves support from a number of processes and helping persons:

- Job Development
- Job Task Analysis
- Testing
- Job Coach
- Community Manager
- Work Trial
- Monitoring or Follow-up

4.13.1 Job Development

The Mid-Level Rehabilitation Worker will need to learn what jobs are available or needed in the community. The MLRW's next step is to identify some specific jobs that may possibly be done by persons with brain injury.

The MLRW will keep in mind some of the special needs and limitations associated with brain injury, as he looks at the various jobs available in the community.

Group or team jobs may be a good work option for a person who needs assistance or supervision. The person with brain injury may be able to work very well as part of a team with other people who are not disabled. Work as a member of a group helps offset individual weaknesses and ensures that the job gets done. Clerical or janitorial jobs often can use a team method. Farming work and factory work can also be organized in teams.

An employer may need to approve special arrangements for the worker who has a brain injury. The person may need a special type of chair, or assistance when lifting job materials. Work tasks may need to be set up in a certain way because the person has problems with seeing or hearing. The person may need to do the job in the same way every day because of problems with learning new information. The MLRW will need to help potential employers understand the reasons for these special needs. The MLRW will also need to help the employer understand that these special arrangements do not have to be expensive and will enable the person to do the work effectively.

4.13.2 Job Task Analysis

This means identifying all the steps or tasks that are involved in a job as well as the order in which they must be done. A job supervisor or a worker who has been doing the job for a long time is the person who can best identify the job tasks.

This information will help a MLRW, a teacher or other community member to determine if the tasks seem possible for a person with brain injury to perform. In addition, knowing the steps will allow a Job Coach to teach the job in small portions. The steps involved in a Job Task Analysis include:

1. Ask the employer for a description of the job. What are the work tasks? How does the employer expect the job to be done? Must the worker stand, use certain tools, or complete the job in a specific amount of time?
2. Observe someone actually doing the job.
3. Write down the steps and specific expectations.

Example: A task analysis of the job of Dish Washer shows that the job includes the following steps:

- Fill basin with soap and water.
- Wash dishes.
- Rinse dishes with fresh water.
- Place dishes in a rack to dry.

4.13.3 Testing

Testing is necessary to find out what kinds of jobs are appropriate for a person with brain injury. Testing helps determine the person's skills and difficulties that can affect his ability to perform certain kinds of jobs. Testing will also help identify what kinds of training and other supports the person will need in order to work at a job.

Testing for skills is different from the tests that a person may take at a school. Testing for work skills involves giving the person tasks to perform and real-life problems to solve. Some abilities to be tested include:

Memory

Can the person remember the steps of a specific task?

Planning and Organization

Can the person plan how to do the task? Can he complete the steps in the proper sequence or does he miss steps?

Problem solving

Can he solve a problem that will be common at the job?

Frustration tolerance

Does the person become frustrated or angry when he can not do a task correctly, or can he remain calm? Can he discuss job problems without becoming angry?

4.13.4 Job Coaching

A Job Coach is a person who knows how to do the job and provides training at the work site for the person with a brain injury. The Job Coach may be another employee or someone who volunteers to learn how to do the job correctly and then trains the person with disability.

Sometimes an employer is reluctant to hire a person who needs training and support in order to do the job. The MLRW can inform the employer that there is a way to make sure the job will be done completely and correctly, even during the time the person is being trained. That way is to allow a Job Coach to provide on-the-job training for the person who has a disability. The Job Coach will agree to complete any work that the person who is being trained does not complete. This guarantees that all job tasks will be done.

The Job Coach reviews the Job Task Analysis and the information gathered through Testing. Then the Job Coach can determine the type of assistance and the amount of assistance that a person will need in order to learn the job.

The Job Coach's responsibilities can include:

- Helping the person to learn the job.
- Helping the person find ways to compensate for physical or thinking problems that affect ability to do the job.
- Helping the person organize the tasks of the job.
- Helping the person interact with other workers.

The amount of Job Coaching depends on the person's progress and the employer's requirements. The Job Coach should regularly meet with the employer to discuss the person's progress. A checklist should be used to review the work requirements and how well the person is meeting the requirements. A checklist may include:

- Tom will arrive at work on time.
- Tom will make 20 cups each day.
- Tom will follow all factory safety rules.

The Job Coach should also give the worker regular information about the employer's expectations. The person then is less likely to feel unfairly judged by the employer. Meetings should be held regularly with the employer so that problems can be corrected before they are so severe that the person loses the job.

As the worker progresses in learning the job, the amount of Job Coaching can be reduced until the person is performing the job alone.

4.13.5 Community Manager

The Community Manager is a family member or perhaps a friend of the injured person, who agrees to help the person with some of the tasks that he must do in order to be able to return to work and keep a job.

The Community Manager must understand the ways that the brain injury affects the person, especially his physical or thinking difficulties.

- A person with brain injury may have difficulty getting to the job site. The Community Manager may help to transport the person to the job.
- The person may need special tools for the job. The Community Manager may need to help him find money to buy tools, or help him to borrow tools.
- The person with brain injury may have difficulty remembering what time to go to work. His Community Manager may help to remind him of the time.
- The person may be having arguments with his wife that causes him to be distracted at work. A Community Manager may help the worker resolve family conflicts that affect his ability to pay attention at work.

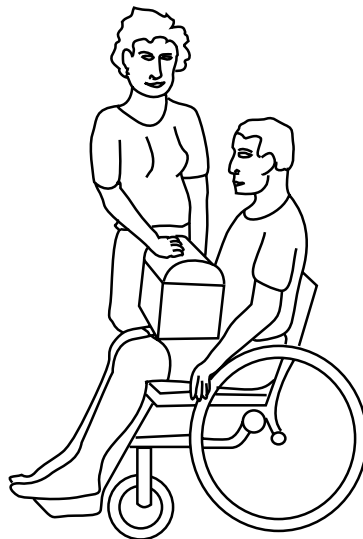

Problems related to other aspects of the person's life may cause him to lose the job, even if he does the actual work tasks correctly. This is why the Community Manager is so important in helping the person with brain injury to keep a job.

4.13.6 Work Trial

A Work Trial is an opportunity to demonstrate that the person with brain injury or other disability can do the job without causing difficulty for the employer or for other workers. A Work Trial can happen after Job Coaching is completed. It is the time the person first does the job alone.

Work Trials are generally scheduled for a limited period of time, depending on the complexity of the job. In a Work Trial, the person with disability is usually not paid. However, he is expected to follow the same rules as paid workers follow. Work Trials can determine if the person can work at the level the employer requires. If the worker's performance is good, the employer may offer a paid job.

Sometimes the employer is not able to offer a paid job to the person with disability because he really does not need another worker. However, the employer may be willing to allow the person to have the experience of training and a Work Trial. Even if a Work Trial does not immediately lead to a paid job, a person can build skills and earn a job reference from the experience.

4.13.7 Monitoring and Follow-up

After a period of time, the Job Coach should return to check that a worker remains successful at the job. Sometimes problems arise that require the Job Coach to provide additional training.

Changes in job requirements may mean that an additional period of Job Coaching is needed. A new work site may require the worker to learn new ways to cope with physical limitations. In the Monitoring stage, the Job Coach meets with both the worker and employer to learn of any new concerns. New information can enable the Job Coach to provide additional help to keep the person on the job.

SUPPORTED EMPLOYMENT IMPROVES WORK SUCCESS

It can greatly enhance the quality of life for persons who have disabilities from a brain injury, or persons with disabilities from other causes. It can be accomplished in a dignified manner with rewarding results for the person, the employer and the entire community.

Reference List

The following references provide additional information that may be useful in the rehabilitation of people with Traumatic Brain Injury. These materials can be obtained from the World Health Organization (WHO)

Training in the Community For People With Disabilities, WHO 1989

This publication consists of 35 booklets: The Introduction, 4 Guides and 30 Training Packages. The Guides and Training Packages that are especially relevant to rehabilitation concerns of people with Traumatic Brain Injury are listed below. These booklets are not available individually.

Guide For School Teachers

Guide For the Community Rehabilitation Committee

Training Packages for Family Members of People Who Have Difficulty Moving:

- *Training Package 8*, Information about the disability and what you can do about it
- *Training Package 9*, How to prevent deformities of the person's arms and legs
- *Training Package 10*, How to prevent sores from pressure on the skin
- *Training Package 12*, How to train the person to move from sitting to standing
- *Training Package 13*, How to train the person to move around
- *Training Package 14*, How to train the person to take care of himself or herself

Training Package for Family Members of a Person Who Has Fits:

- *Training Package 21*, Information about the disability and what you can do about it

Training Package for a Family Member of a Child With a Disability:

- *Training Package 27*, Schooling

Training Package for a Family Member of a Person With a Disability:

- *Training Package 29, Household activities*
- *Training Package 30, Job placement*

Promoting Independence Following a Spinal Cord Injury: A Manual for Mid-Level Rehabilitation Workers, WHO 1996

Requests for these manuals may be sent to:

Dr. Enrico Pupulin
Disability and Rehabilitation
World Health Organization
1211 Geneva 27
Switzerland

These materials may be sent free of charge to organizations or individuals from developing countries